

brother

TWIN NEEDLE, NEEDLE FEED LOCK STITCHER

DOPPELNADEL-VERRIEGELUNGSSTICHMASCHINE MIT NADELTRANSPORT

MACHINE À DOUBLE AIGUILLE POUR POINT D'ARRÊT AVEC ENTRAÎNEMENT PAR AIGUILLES

MÁQUINA DE DOBLE PESPUNTE CON TRANSPORTE DE AGUJA Y DOS AGUJAS

LT2-B832

PARTS BOOK

TEILEKATALOG

LIVRE DES PIÈCES

LIBRO DE REFERENCIA DE PIEZAS

P832502

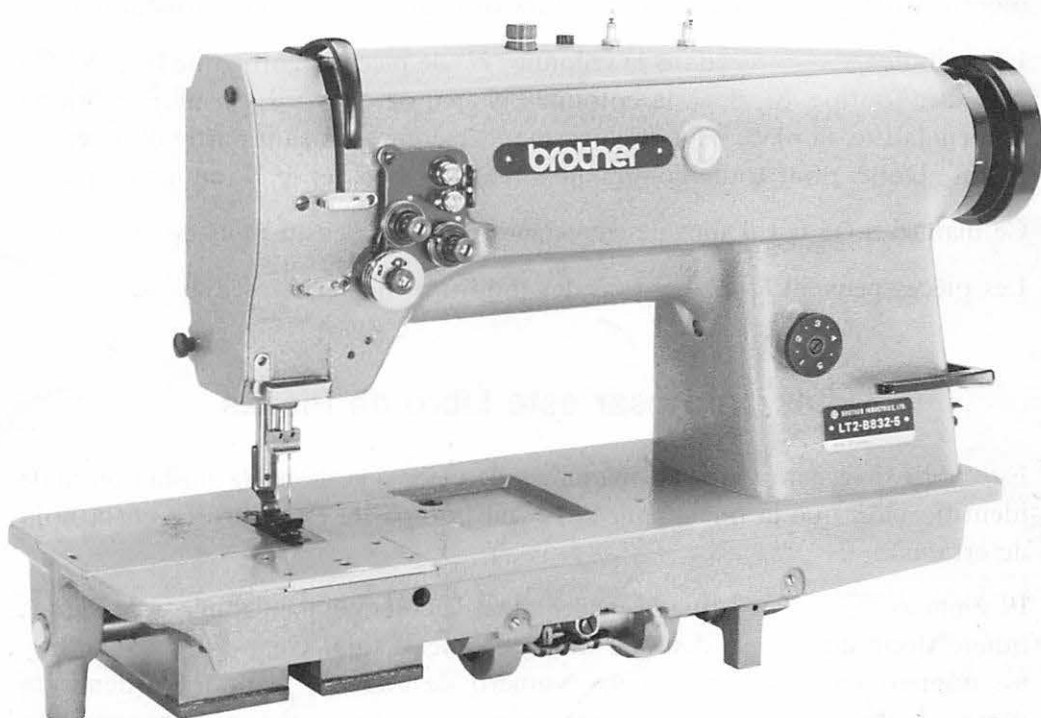

Notes for using this parts book

1. This book is applicable to sewing machines which have the same plate number as shown on the cover of this book (or correction sheet).
2. The symbol  in the "Parts No." column indicates that the parts is not available for supply. If, however, there is a number in the "Assembly No." column, the parts can be ordered as an assembly. Please, therefore, order by using the Assembly No.
3. This book was prepared based on information available in June, 1983.
4. Parts are subject to changes in design without prior notice.

Anmerkungen zum Gebrauch dieses Stücklistebuches

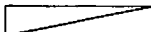
1. Dieses Buch bezieht sich auf die Nähmaschinen mit derselben Kennungsnummer wie auf diesem Buchumschlag (oder auf dem Korrekturblatt).
2. Dieses Zeichen  in der Spalte "Teilnummer" bedeutet, daß dieser Teil nicht lieferbar ist. Wenn jedoch in der Spalte "Gerätesatznummer" eine Nummer steht, kann dieser Teil als ein Geräteteilsatz bestellt werden. Bestellen Sie daher bitte mit dieser Gerätesatznummer.
3. Dieses Buch basiert auf den Informationen vom Juni, 1983.
4. Modelländerungen sind vorbehalten.

Notes sur l'utilisation de ce manuel de pièces détachées

1. Ce manuel est destiné aux machines à coudre ayant le même numéro de plaque montré sur la couverture de ce manuel (ou sur la feuille de corrections).
2. Le symbole  dans la colonne "N° de pièce" signifie que la pièce ne peut être fournie. Si, dans la colonne "N° jeu de pces", il y a un numéro de nomenclature, la pièce peut être commandée comme faisant partie d'un jeu de pièces. Donc, pour toute commande, veuillez spécifier le N° de jeu de pièces.
3. Ce manuel a été fait d'après les renseignements valables au mois de Juin, 1983.
4. Les pièces peuvent être sujettes à des modifications sans préavis.

Notas para usar este Libro de Piezas

1. Este libro sirve para todas las máquinas de coser que llevan la misma placa de identificación que la que se puede ver en la tapa de este libro (o en la hoja de erratas).
2. El símbolo , que se encuentra en la columna del "Número de Pieza", quiere decir que no se dispone de dicha pieza sola. Cuando, empero, hay un número en la columna del "Numero de Juego", se podrá ordenar la pieza con todo el juego. Por lo tanto, será mejor hacer el pedido recurriendo al número del juego respectivo.
3. Este libro ha sido compilado basándose en los datos de que se disponía en junio de 1983.
4. Las piezas quedan sujetas a cambios de diseño sin aviso previo.

CONTENTS

A. Machine body.....	1
B. Threading mechanism (1).....	2
B. Threading mechanism (2)[Standard]	2
B. Threading mechanism (3) [-400A•-700A].....	3
C. Upper shaft mechanism	3
D. Needle bar rocking mechanism	4
E. Presser foot mechanism (1).....	5
E. Presser foot mechanism (2) [Standard•-400A]	5
E. Presser foot mechanism (3)[-700A]	6
F. Feed mechanism (1).....	6
F. Feed mechanism (2)[Standard].....	7
F. Feed mechanism (3)[-400A•-700A].....	7
G. Quick reverse mechanism[-400A•-700A].....	8
H. Feed shaft mechanism	8
J. Rotary hook mechanism (1).....	9
J. Rotary hook mechanism (2)[Standard].....	9
J. Rotary hook mechanism (3) [-400A•-700A].....	10
K. Lower shaft mechanism	10
L. Lubrication (1)	11
L. Lubrication (2)[Standard].....	12
L. Lubrication (3)[-400A•-700A].....	13
M. Thread wiper mechanism[-400A•-700A]... 14	
N. Quick reverse switch mechanism [-400A•-700A].....	14
P. Thread trimmer mechanism [-400A•-700A].....	15
Q. Tension release mechanism [-400A•-700A].....	16
R. Synchronizer (1)[-400A•-700A]	17
S. Gauge parts mechanism	17
T. Control box mechanism (1) [-700A BROTHER Motor].....	18
U. Treadle mechanism (Option parts).....	19
Z. Accessories (1).....	20
Z. Accessories (2).....	21
Gauge parts list.....	22
INDEX	24

INHALTSVERZEICHNIS

A. Maschinengehäuse.....	1
B. Fadenführungsvorrichtung (1)	2
B. Fadenführungsvorrichtung (2)[Norm].....	2
B. Fadenführungsvorrichtung (3) [-400A•-700A].....	3
C. Obere Welle	3
D. Nadelstangenbetätigung	4
E. Stoffdrückerfuß (1).....	5
E. Stoffdrückerfuß (2)[Norm•-400A].....	5
E. Stoffdrückerfuß (3)[-700A].....	6
F. Transportvorrichtung (1).....	6
F. Transportvorrichtung (2)[Norm]	7
F. Transportvorrichtung (3)[-400A•-700A]	7
G. Umkehr[-400A•-700A].....	8
H. Transport welle.....	8
J. Greifervorrichtung (1).....	9
J. Greifervorrichtung (2)[Norm]	9
J. Greifervorrichtung (3)[-400A•-700A].....	10
K. Untere welle.....	10
L. Schmierung (1)	11
L. Schmierung (2)[Norm].....	12
L. Schmierung (3)[-400A•-700A].....	13
M. Fadenwischvorrichtung[-400A•-700A]	14
N. Umkehrschalter[-400A•-700A].....	14
P. Fadenabschneidevorrichtung [-400A•-700A].....	15
Q. Spannung sverminderung svorrichtung [-400A•-700A].....	16
R. Synchronisator (1)[-400A•-700A].....	17
S. Lehren.....	17
T. Schaltkasten (1) [-700A BROTHER Motor].....	18
U. Pedal (Option parts).....	19
Z. Zubehör (1)	20
Z. Zubehör (2)	21
Lehrenliste.....	22
VERZEICHNIS.....	24

TABLE DES MATIERES

A. Corps de la machine.....	1
B. Mécanisme de Jénfilage (1).....	2
B. Mécanisme de Jénfilage (2)[Standard].....	2
B. Mécanisme de Jénfilage (3) [-400A•-700A].....	3
C. Mécanisme de l'arbre superieur.....	3
D. Mécanisme de balancement de la barre à aiguille.....	4
E. Mécanisme du pied presseur (1).....	5
E. Mécanisme du pied presseur (2) [Standard•-400A].....	5
E. Mécanisme du pied Presseur (3)[-700A].....	6
F. Mécanisme de l'entraînement (1).....	6
F. Mécanisme de l'entraînement (2)[Standard].....	7
F. Mécanisme de l'entraînement (3) [-400A•-700A].....	7
G. Mécanisme de marche arrière rapide [-400A•-700A].....	8
H. Mécanisme de l'arbre entraînement.....	8
J. Mécanisme du crochet rotatif (1).....	9
J. Mécanisme du crochet rotatif (2)[Standard].....	9
J. Mécanisme du crochet rotatif (3) [-400A•-700A].....	10
K. Mécanisme de l'arbre inférieur.....	10
L. Lubrification (1).....	11
L. Lubrification (2)[Standard].....	12
L. Lubrification (3)[-400A•-700A].....	13
M. Mécanisme de tire-fil[-400A•-700A].....	14
N. Mécanisme de interrupteur de marche arrière rapide[-400A•-700A].....	14
P. Mécanisme de coupe-fill[-400A•-700A].....	15
Q. Mécanisme de relâche-tension [-400A•-700A].....	16
R. Synchronisateur (1)[-400A•-700A].....	17
S. Pièces d'écartement.....	17
T. Mécanisme du boîtier de contrôle (1) [-700A BROTHER Moteur].....	18
U. Mécanisme de la pédale[Pièces en option].....	19
Z. Accessoires (1).....	20
Z. Accessoires (2).....	21
Liste des pièces d'écartement.....	22
INDEX.....	24

INDICE

A. Denominación del mecanismo.....	1
B. Mécanismo de la enhebrado (1).....	2
B. Mécanismo de la enhebrado (2)[Norma].....	2
B. Mécanismo de la enhebrado (3) [-400A•-700A].....	3
C. Mécanismo de la eje superior.....	3
D. Mécanismo de oscilación de la barra de aguja.....	4
E. Mécanismo del prensa telas (1).....	5
E. Mécanismo del prensa telas (2) [Norma•-400A].....	5
E. Mécanismo del prensa telas (3)[-700A].....	6
F. Mécanismo de la alimentación (1).....	6
F. Mécanismo de la alimentación (2)[Norma].....	7
F. Mécanismo de la alimentación (3) [-400A•-700A].....	7
G. Mécanismo de inversión rápida [-400A•-700A].....	8
H. Mécanismo de la eje alimentación.....	8
J. Mécanismo del cangrejo (1).....	9
J. Mécanismo del cangrejo (2)[Norma].....	9
J. Mécanismo del cangrejo (3) [-400A•-700A].....	10
K. Mécanismo de la eje inferior.....	10
L. Lubricación (1).....	11
L. Lubricación (2)[Norma].....	12
L. Lubricación (3)[-400A•-700A].....	13
M. Mécanismo de limpiador de hilos [-400A•-700A].....	14
N. Mécanismo de conmutador de inversión rápida [-400A•-700A].....	14
P. Mécanismo de recortadora de orillos [-400A•-700A].....	15
Q. Mécanismo de liberador de tensión [-400A•-700A].....	16
R. Sincronizador (1)[-400A•-700A].....	17
S. Piezas calibradoras.....	17
T. Mécanismo del caja de controles (1) [-700A BROTHER Motor].....	18
U. Mécanismo de la pedal[Piezas opción].....	19
Z. Accesorios (1).....	20
Z. Accesorios (2).....	21
Lista de piezas calibradoras.....	22
INDICE.....	24

A. Machine body / Maschinengehäuse
 Corps de la machine / Denominación del mecanismo

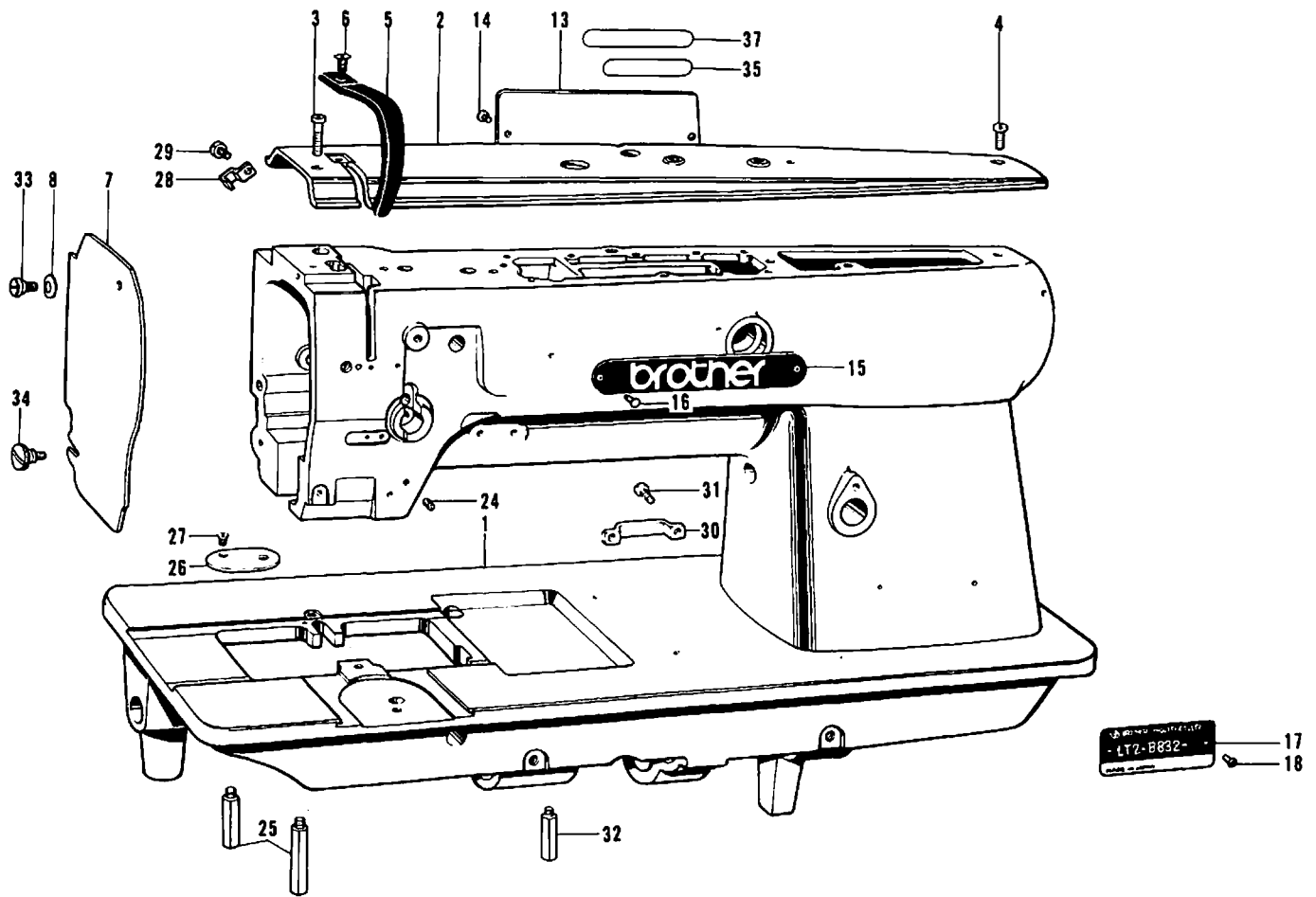

Ref. No.	Name of Parts	Q'ty	Parts No.	Assembly No.	Ref. No.	Name of Parts	Q'ty	Parts No.	Assembly No.
1	Arm Bed	1			24	Screw 4.37	2	151602-0-02	
2	Arm Top Cover	1	112560-0-03		25	Bed Leg (for Thread Trimmer)	2	148611-0-01	
3	Screw 437-40 x 16	1	062681-6-12		26	Cover (for Thread Trimmer)	1	148614-0-01	
4	Screw 437-40 x 10	1	062681-0-12		27	Screw 3.18 (for Thread Trimmer)	2	149288-0-02	
5	Thread Take-up Cover	1	112561-0-03		28	Tube Holder (L))(for Thread Trimmer)	2	142268-0-01	
6	Screw 4.76	1	107231-0-02		29	Screw 357-40 x 6 (for Thread Trimmer)	2	062670-6-12	
7	Face Plate	1	151101-0-02		30	Cord Holder (LL))(for -400A, -700A)	1	148818-0-01	
8	Washer	1	146598-0-01		31	Screw 357-40 x 6	2	062670-6-12	
13	Rear Cover	1	112566-0-03		32	Bed Leg (Small)	1	149179-0-01	
14	Screw 357-40 x 6	2	062670-6-12		33	Screw 3.57	1	153112-0-01	
15	Name Plate	1			34	Screw 3.57	1	129984-0-02	
16	Pin	2			35	Name Plate	1		
17	Model Plate	1			37	Parts Book Number Plate	1		
18	Pin	2							

B. Threading mechanism (1)
 Fadenführungsvorrichtung (1)
 Mécanisme de Jénfilage (1)
 Mécanismo de la enhebrado (1)

B. Threading mechanism (2)[Standard]
 Fadenführungsvorrichtung (2)[Norm]
 Mécanisme de Jénfilage (2)[Standard]
 Mécanismo de la enhebrado (2)[Norma]

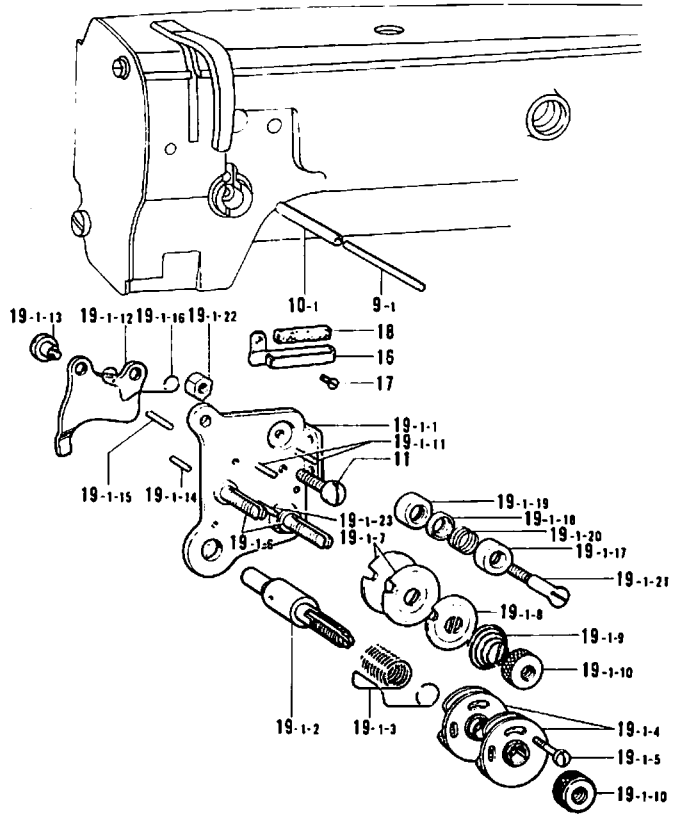
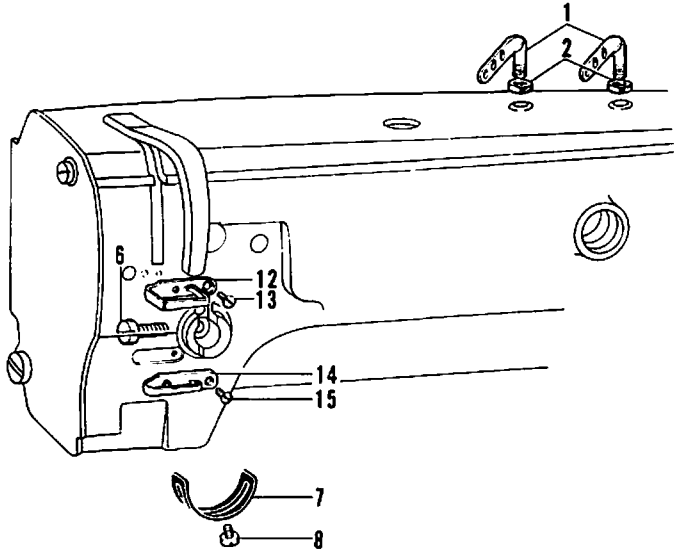

Ref. No.	Name of Parts	Q'ty	Parts No.	Assembly No.
1	Top Cover Therad Guide	2	140527-0-01	
2	Nut 5.95	2	150553-0-03	
6	Screw 3.57	1	100064-0-02	
7	Stopper	1	112709-0-01	
8	Screw 357-40 x 6	1	062670-6-12	
12	Arm Thread Guide (Upper)	1	108266-0-01	
13	Screw 3.57	1	108960-0-02	
14	Arm Thread Guide (Center)	1	112658-0-01	
15	Screw 3.57	1	108960-0-02	

Ref. No.	Name of Parts	Q'ty	Parts No.	Assembly No.
9-1	Tension Release Bar	1	144823-0-01	
10-1	Pipe	1	112714-0-00	
11	Screw 437-40 x 10	1	062681-0-12	
16	Arm Thread Guide (Lower)	1	112715-0-01	
17	Screw 3.57	1	108960-0-02	
18	Felt	1	114941-0-01	
19-1- 1	Upper Thread Tension Plate	1		
19-1- 2	Tension Stud	1	144680-0-01	
19-1- 3	Thread Take-up Spring	1	144681-0-01	
19-1- 4	Spring Guide Assembly	2	108254-0-01	
19-1- 5	Screw 2.38	1	144682-0-01	
19-1- 6	Tension Stud	2	112706-0-01	
19-1- 7	Tension Disc	4	108263-0-01	
19-1- 8	Tension Disc Washer	2	108264-0-01	
19-1- 9	Tension Spring (for-1,-3)	2	118317-0-01	
	Tension Spring (for-5)	2	148924-1-01	
19-1-10	Tension Control Nut	3	108265-0-01	B-19-1 Upper Tension Control Assembly (for-1,-3) 144678-0-01 (for-5) 148011-1-01
19-1-11	Pin	2		
19-1-12	Tension Release Plate	1	144683-0-01	
19-1-13	Stud Screw 3.57	2	112712-0-01	
19-1-14	Pin	1	144703-0-01	
19-1-15	Pin	1	144704-0-01	
19-1-16	Tension Release Spring	2	118320-0-01	
19-1-17	Cap	2	144685-0-01	
19-1-18	Disc	2	144686-0-01	
19-1-19	Thread Guide Bracket	2	144687-0-01	
19-1-20	Thread Guide Spring	2	144688-0-01	
19-1-21	Stud Screw	2	144689-0-01	
19-1-22	Nut 3.57	2	021670-1-02	
19-1-23	Pin	2		

B. Threading mechanism (3)[-400A..700A]
 FadenführungsVorrichtung (3)[-400A..700A]
 Mécanisme de Jénfilage (3)[-400A..700A]
 Mecanismo de la enhebrado (3)[-400A..700A]

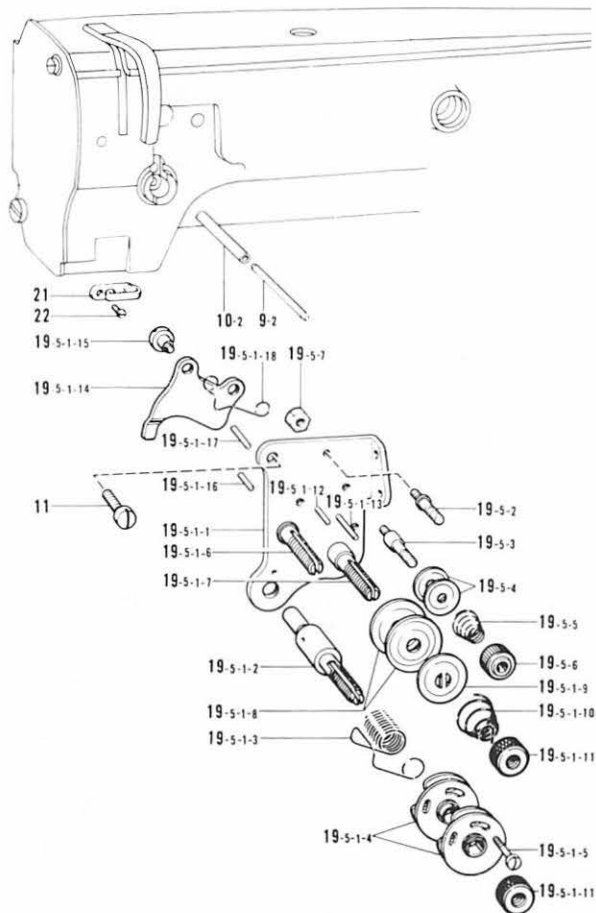

Ref. No.	Name of Parts	Q'ty	Parts No.	Assembly No.
9-2	Thread Tension Releaser	1	112713-0-01	
10-2	Pipe	1	148604-0-00	
11	Screw 437-40 x 10	1	062681-0-12	
19-5-1- 1	Upper Thread Tension Plate	1		
19-5-1- 2	Tension Stud	1	144680-0-01	
19-5-1- 3	Thread Take-up Spring	1	155491-0-01	
19-5-1- 4	Spring Guide	2	108254-0-01	
19-5-1- 5	Screw 2.38	1	144682-0-01	
19-5-1- 6	Tension Stud	1		
19-5-1-17	Tension Stud (R)	1		
19-5-1- 8	Tension Disc	4	145446-0-01	
19-5-1- 9	Presser for Tension Disc	2	159805-0-01	
19-5-1-10	Tension Spring	2	155492-0-01	
19-5-1-11	Tension Control Nut	3	108265-0-01	
19-5-1-12	Pin	1		
19-5-1-13	Pin 2.6 x 20	1		
19-5-1-14	Tension Release Plate	1	144683-0-01	
19-5-1-15	Stud Screw 3.57	2	112712-0-01	
19-5-1-16	Pin	1	144703-0-01	
19-5-1-17	Pin (R)	1	158769-0-01	
19-5-1-18	Tension Release Spring	1	118320-0-01	
19-5-2	Thread Guide Shaft (L)	1	158771-0-01	
19-5-3	Thread Guide Shaft (R)	1	158770-0-01	
19-5-4	Thread Guide Disc	4	144504-0-01	
19-5-5	Pre-Tension Spring	2	158782-1-01	
19-5-6	Nut	2	155510-0-01	
19-5-7	Nut 3.57	2	021670-1-02	
21	Arm Thread Guide (Center)	1	112658-0-01	
22	Screw 3.57	1	108960-0-02	

B-19-5
 Upper Tension
 Control Assembly
 158764-1-01

C. Upper shaft mechanism
 Obere welle
 Mécanisme de larbre superior
 Mecanismo de la eje superior

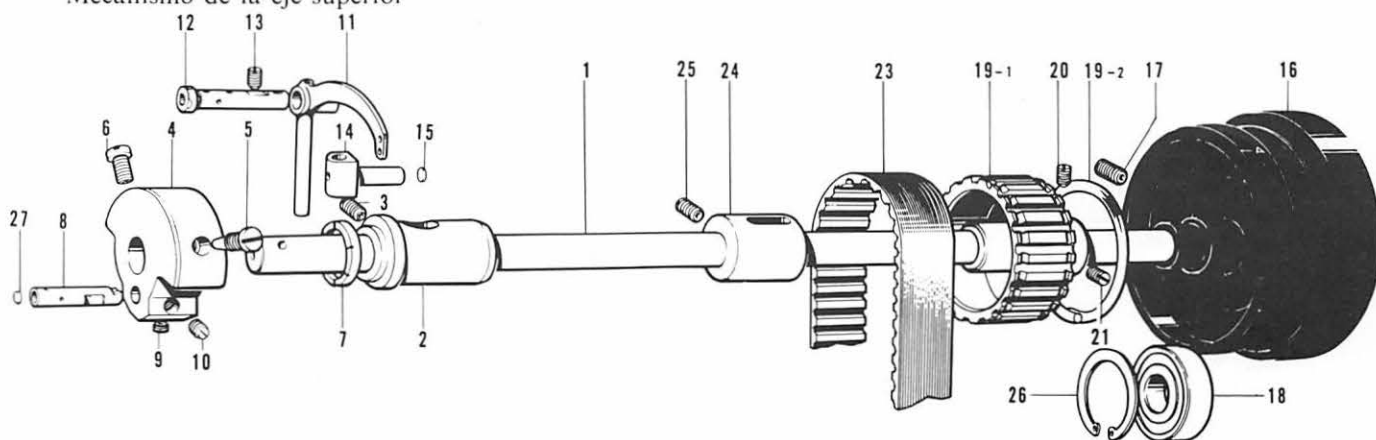

Ref. No.	Name of Parts	Q'ty	Parts No.	Assembly No.	Ref. No.	Name of Parts	Q'ty	Parts No.	Assembly No.
1	Upper Shaft	1	112572-0-01		15	Pusher	1	113024-0-00	
2	Upper Shaft Bushing (Left)	1	112573-0-01		16	Pulley (for Standard)	1	144614-0-01	
3	Screw 5.95	1	013761-4-10		17	Pulley (for Thread Trimmer)	1	158749-0-01	
4	Counter Weight	1	112574-0-00		19-1	Timing Belt Wheel (Upper)	1		
5	Screw 7.14	1	100250-0-01		19-2	Side Ring	2		
6	Screw 7.14	1	146141-0-01		20	Screw 6.35 x 12	1	015771-2-12	
7	Thrust Ring	1	112576-0-01		21	Screw 6.35 x 12	1	013771-2-12	
8	Needle Bar Crank	1	112577-0-01		23	Timing Belt	1	112586-0-01	
9	Screw 6.35	1	101706-0-01		24	Upper Shaft Bushing (Center)	1	114680-0-01	
10	Screw 6.35	1	100251-0-01		25	Screw 5.95	1	013761-4-10	
11	Thread Take-up (for Standard-5)	1	140525-0-01		26	Stop Ring (C)	1	112760-0-01	
	Thread Take-up (for Thread Trimmer) (for Standard-1,-3)	1	112578-0-01		27	Pusher	1	113014-0-01	
12	Stud	1	112579-0-01						
13	Screw 5.95	1	013761-4-10						
14	Thread Take-up Lever Slide Brock	1	118171-0-01						

C-19
 Timing Belt Wheel
 Upper Assembly
 180157-0-01

D. Needle bar rocking mechanism / Nadelstangenbetätigung
 Mécanisme de balancement de la barre à aiguille / Mecanismo de oscilación de la barra de aguja

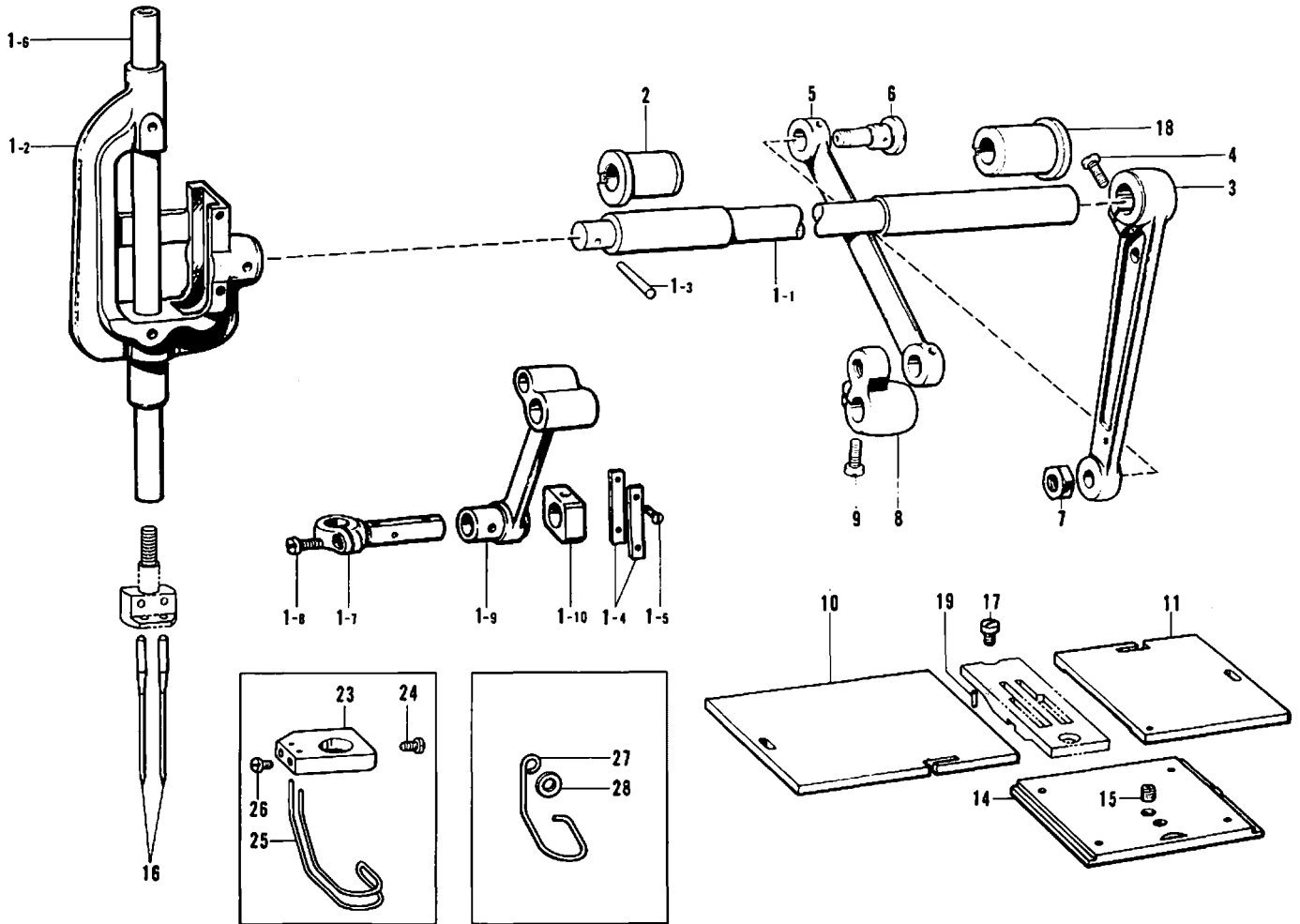

Ref. No.	Name of Parts	Q'ty	Parts No.	Assembly No.	Ref. No.	Name of Parts	Q'ty	Parts No.	Assembly No.		
1- 1	Needle Bar Rock Shaft	1		D-1 Needle Bar Crank Rod Assembly 159359-0-01	10	Slide Plate (Left) 31.8 ~ 38.1 mm	1	145721-0-01			
1- 2	Needle Bar Support	1	112589-1-00			11	Slide Plate (Left) 50.8 ~ 55.0 mm	1	150836-0-01		
1- 3	Taper Pin	1	107030-0-01			14	Slide Plate Front Assembly (for Standard)	1	112610-0-01		
1- 4	Needle Bar Guide Plate	2	112590-0-01				Slide Plate Front Assembly (for Thread Trimmer)	1	148599-0-01		
1- 5	Screw 2.38	4	102731-0-04			15	Screw 5.16	1	116010-0-01		
1- 6	Needle Bar	1	159360-0-01			16	Needle DP x 5 #11 (for-1)	2	107415-0-11		
1- 7	Needle Bar Clamp	1	112592-0-01					Needle DP x 5 #14 (for-3)	2	107415-0-14	
1- 8	Screw 357-40 x 8	1	062670-8-12					Needle DP x 5 #21 (for-5)	2	107415-0-21	
1- 9	Needle Bar Clank Rod	1	112593-0-01					Needle DP x 5 #22 (for-5)	2	107415-0-22	
1-10	Needle Bar Guide Slide Block	1	112721-0-01			17	Screw 3.57	1	112751-0-03		
2	Needle Bar Rock Shaft Bushing (Left)	1	112594-0-01		18	Needle Bar Rock Shaft Bushing (Right)	1	112764-0-01			
3	Needle Bar Connecting Rod	1	112595-0-00		19	Pin	1	113386-0-00			
4	Screw 6.35	1	105351-0-02		23	Finger Guard Supporter (for Standard-Option)	1	151191-0-01			
5	Needle Bar Rock Link	1	112596-0-01		24	Screw 3.57 (for Standard-Option)	1	144458-0-01			
6	Needle Bar Rock Link Stud	2	112597-0-01		25	Finger Guard (for Standard-Option)	1	150917-0-01			
7	Nut 7.94	2	101268-0-02		26	Screw (for Standard-Option)	2	149177-0-01			
8	Needle Bar Connecting Crank	1	112598-0-01		27	Finger Guard (for Thread Trimmer-Option)	1	155522-0-01			
9	Screw 6.35 x 18	1	009781-8-12		28	Washer 4.76 (for Thread Trimmer-Option)	1	153484-0-01			
10	Slide Plate (Left) 0.5 ~ 25.4 mm	1	112606-0-01								

E. Presser foot mechanism (1)
 Stoffdrückerfuß (1)
 Mécanisme du pied presseur (1)
 Mecanismo del prensa telas (1)

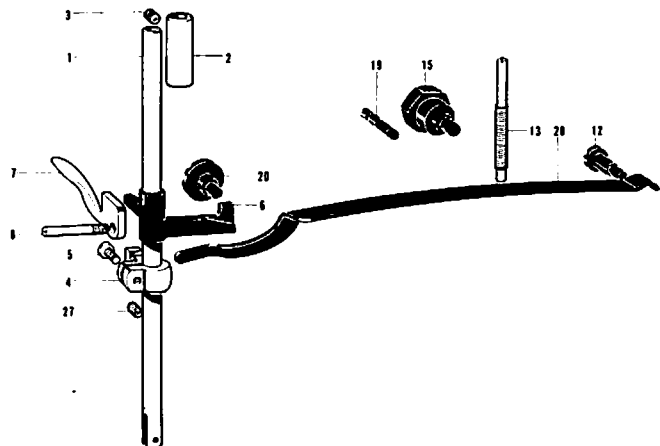

Ref. No.	Name of Parts	Q'ty	Parts No.	Assembly No.
1	Presser Bar	1	112614-0-01	
2	Presser Bar Bushing (Upper)	1	112615-0-01	
3	Screw 5.95	1	013760-6-10	
4	Presser Bar Bracket	1	112616-0-01	
5	Screw 357-40 x 8	1	062670-8-12	
6	Presser Bar Lifter	1	148483-0-01	
7	Presser Foot Lifter	1	112618-0-01	
8	Screw	1	112619-0-01	
12	Stud Screw 6.35	1	112623-0-01	
13	Presser Adjusting Screw	1	112624-0-01	
15	Stud Screw 6.35	1	112626-0-01	
19	Stopper Screw	1	112630-0-01	
20	Screw	1	112631-0-01	
27	Screw 5.95	1	151605-0-01	
28	Presser Plate Spring	1	118170-1-01	

E. Presser foot mechanism (2)[Standard-400A]
 Stoffdrückerfuß (2)[Norm-400A]
 Mécanisme du pied presseur (2)[Standard-400A]
 Mecanismo del prensa telas (2)[Norma-400A]

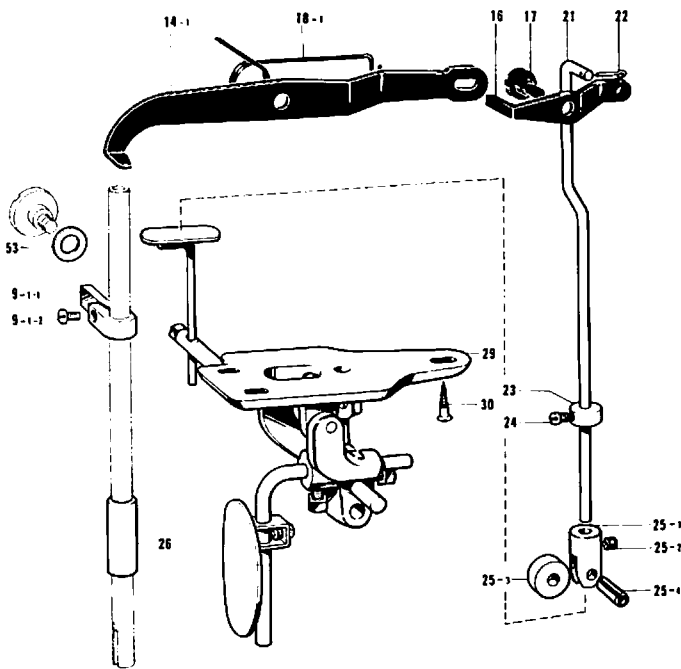

Ref. No.	Name of Parts	Q'ty	Parts No.	Assembly No.
9-1-1	Presser Bar Guide	1		E-9-1 Presser Bar Guide Assembly (for Standard) 180950-0-01 (for 400A) 148835-0-01
9-1-2	Screw 437-40 x 7	1	062680-7-12	
14-1	Knee Lifter Connecting Lever (for Standard)	1	112625-0-01	
	Knee Lifter Connecting Lever (for-400A)	1	148486-0-01	
16	Knee Lifter Lever	1	155505-0-01	
17	Stud Screw 6.35	1	112628-0-01	
18-1	Spring	1	112629-0-01	
21	Knee Lifter Connecting Rod	1	155447-1-01	
22	Pin	1	114909-0-00	
23	Set Collar	1	159436-0-01	
24	Screw 4.37	1	104908-0-04	
25-1	Roller Bracket	1		E-25 Knee Lifter Roller Assembly 156824-0-01
25-2	Screw 4.37	1	151601-0-02	
25-3	Roller	1	112636-0-01	
25-4	Spring Pin AW5	1	047501-2-42	
26	Presser Bar Bushing (Lower)(for Standard)	1	112763-0-01	
	Knee Lifter Assembly (for Standard)	1	113380-0-01	
	Knee Lifter Assembly (for-400A)	1	148674-0-01	
30	Screw 6.2 x 32	3	106030-0-01	
53	Collar (for-400A)	1	148605-0-01	

E. Presser foot mechanism (3)[-700A]
 Stoffdrückerfuß (3)[-700A]
 Mécanisme du pied Presseur (3)[-700A]
 Mecanismo del prensa telas (3)[-700A]

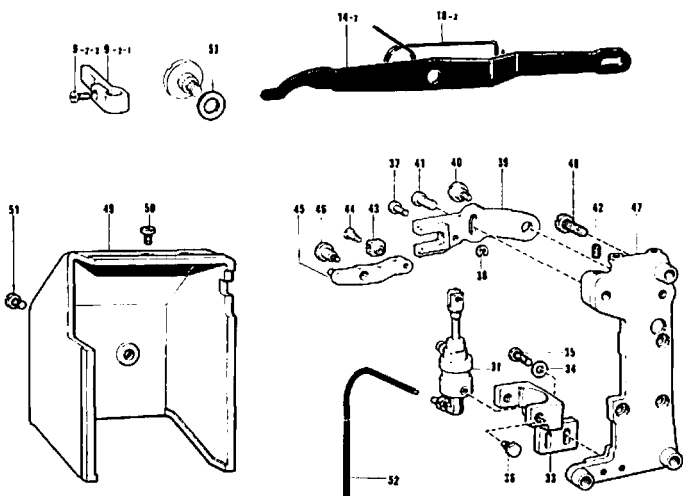

Ref. No.	Name of Parts	Q'ty	Parts No.	Assembly No.
9-2-1	Presser Bar Guide	1		E-9-2 Presser Bar Guide Assembly 148835-0-01
9-2-2	Screw 437-40 x 7	1	062680-7-12	
14-2	Knee Lifter Connecting Lever	1	148486-0-01	
18-2	Spring	1	149768-0-01	
31	Presser Foot Lifter Cylinder (for-700A)	1	159621-0-01	
33	Cylinder Supporter	1	159605-0-01	
34	Washer 4.76	2	025710-2-32	
35	Screw 476-32 x 16	2	062711-6-12	
36	Screw	2	140620-0-01	
37	Pin	1	146153-0-01	
38	Stop Ring E4	1	048040-3-42	
39	Presser Foot Lifter Lever	1	149024-0-01	
40	Stud Screw 6.35	1	141439-0-01	
41	Pin	1	118713-0-01	
42	Screw 4.76	1	013710-7-12	
43	Slide Block Assembly	1	149025-0-01	
44	Screw	1	141494-0-01	
45	Lever Assembly	1	149027-0-01	
46	Screw 6.35	1	149991-0-01	
47	Cylinder Base	1	159606-0-01	
48	Screw 635-28 x 25	3	062782-5-12	
49	Cylinder Cover	1	159607-0-01	
50	Screw 476-32 x 8	2	062710-8-12	
51	Screw 5 x 6	1	007500-6-02	
52	Air Tube	1	159608-0-01	
53	Collar	1	148605-0-01	

F. Feed mechanism (1)
 Transportvorrichtung (1)
 Mécanisme de l'alimentement (1)
 Mecanismo de la alimentación (1)

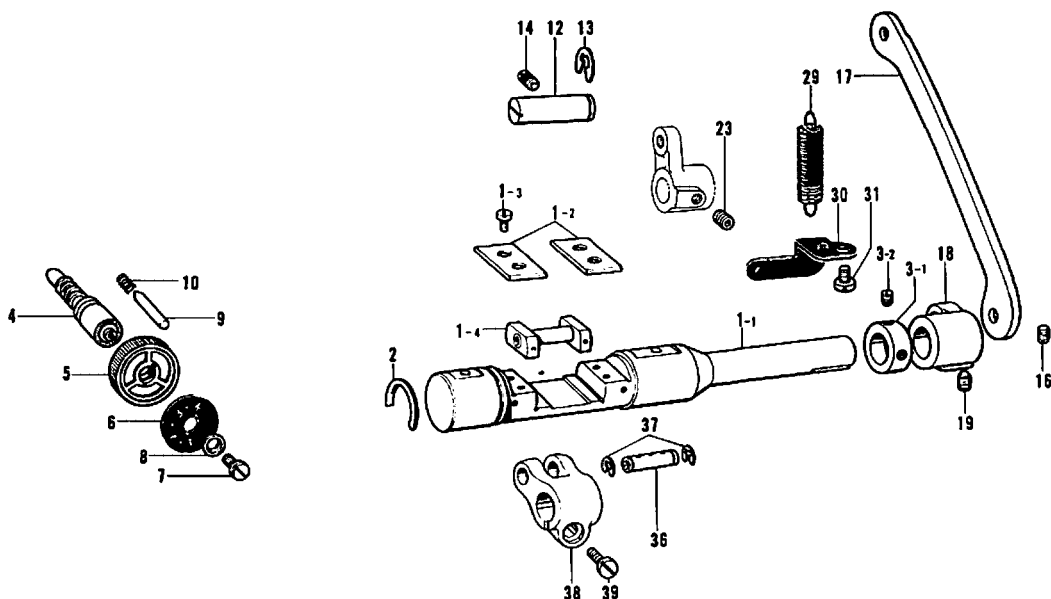

Ref. No.	Name of Parts	Q'ty	Parts No.	Assembly No.	Ref. No.	Name of Parts	Q'ty	Parts No.	Assembly No.
1-1	Feed Regulator Shaft	1		F-1	13	Stop Ring E7	1	048070-3-42	
1-2	Slide Block Guide Plate	2	143594-0-01	Feed Regulator Shaft Assembly 148771-0-01	14	Screw 5.95	1	013761-4-10	
1-3	Screw 437-40 x 10	4	062681-0-12		16	Screw 4.37	2	151602-0-01	
1-4	Slide Block Assembly	1	145328-0-01	17	Feed Regulator Connecting Link	1	148487-0-01		
2	Stop Ring	1	143597-0-01	18	Feed Regulator Arm (for-1,-3)	1	148499-0-01		
3-1	Collar	1		F-3 Collar Assembly 180321-0-01	19	Feed Regulator Arm (for-5)	1	148500-0-01	
3-2	Screw 6.35	2	101706-0-01		19	Screw 5.95	1	118853-0-01	
4	Length Control Screw	1	159361-0-01	23	Screw 5.95	1	118853-0-01		
5	Length Control Dial	1	153168-0-01	29	Spring	1	143609-0-01		
6	Length Control Plate (for-1,-3)	1	151508-0-01	30	Spring Hook Plate	1	143610-0-01		
	Length Control Plate (for-5)	1	151507-0-01	31	Screw 476-32 x 8	1	062710-8-12		
7	Screw 4.76	1	142747-0-02	36	Stud	1	143616-0-01		
8	Washer	1	142746-0-02	37	Stop Ring E6	2	048060-3-42		
9	Pin	1	145502-0-01	38	Lever Feed Arm	1	148495-0-01		
10	Notch Spring	1	100328-0-01	39	Screw 6.35 x 18	1	009781-8-12		
12	Feed Regulator Stud	1	148488-0-01						

F. Feed mechanism (2)[Standard]
 Transportvorrichtung (2)[Norm]
 Mécanisme de l'entraînement (2)[Standard]
 Mecanismo de la alimentación (2)[Norma]

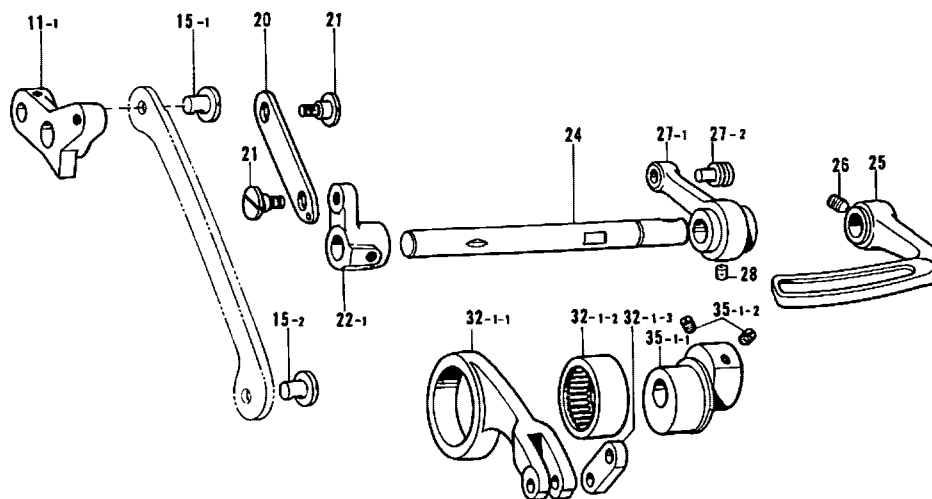

Ref. No.	Name of Parts	Q'ty	Parts No.	Assembly No.	Ref. No.	Name of Parts	Q'ty	Parts No.	Assembly No.
11-1	Feed Regulator	1	148489-0-01		27-1	Link (B)	1		F-27 Link Assembly 143608-0-01
15-1	Pin	1	118713-0-01		27-2	Spring Hook	1		
15-2	Pin	1	148501-1-01		28	Screw 5.95 x 6	1	014760-6-22	
20	Connecting Plate	1	118746-0-01		32-1-1	Level Feed Connecting Rod	1	143612-0-00	F-32-1 Level Feed Connection Rod Assembly 143611-0-01
21	Stud Screw 4.37	2	112072-0-01		32-1-2	Needle Bearing	1	118954-0-00	
22-1	Lever	1	118747-0-01		32-1-3	Level Feed Connecting Link	1	143613-0-01	
24	Feed Legulator Lever Shaft	1	151080-0-01		35-1-1	Eccentric Wheel	1		F-35-1 Eccentric Wheel Assembly 148802-0-01
25	Reverse Lever	1	118752-0-03		35-1-2	Screw 5.95	2	151605-0-01	
26	Screw 6.35 x 10	1	015771-0-12						

F. Feed mechanism (3)[-400A.-700A]
 Transportvorrichtung (3)[-400A.-700A]
 Mécanisme de l'entraînement (3)[-400A.-700A]
 Mecanismo de la alimentación (3)[-400A.-700A]

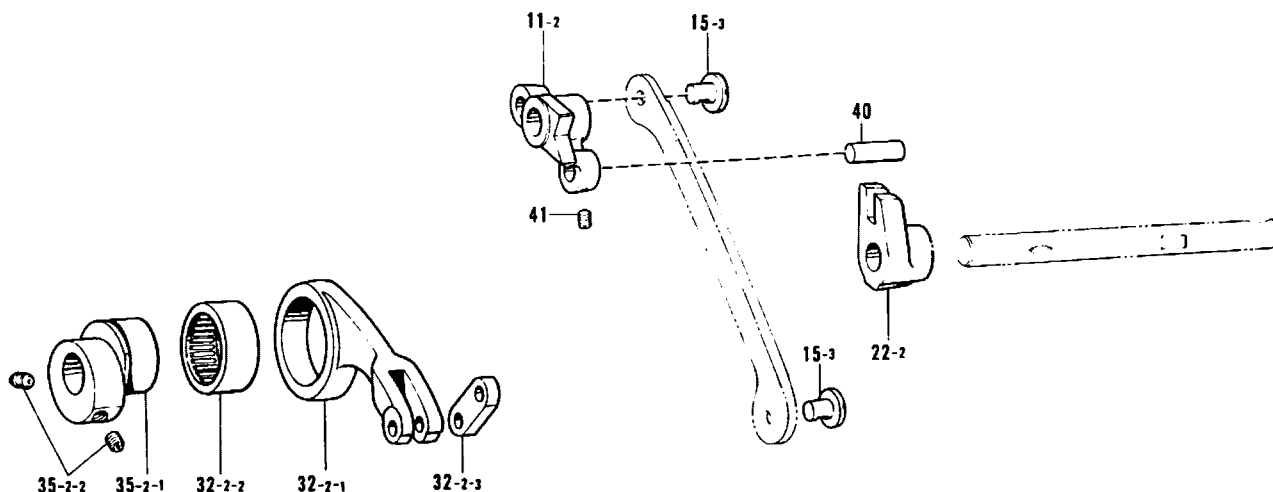

Ref. No.	Name of Parts	Q'ty	Parts No.	Assembly No.	Ref. No.	Name of Parts	Q'ty	Parts No.	Assembly No.
11-2	Feed Regulator	1	158747-0-01		35-2-1	Eccentric Wheel	1		F-35-2 Eccentric Wheel Assembly 155451-0-01
15-3	Pin	2	148501-1-01		35-2-2	Screw 5.95	2	151605-0-01	
22-2	Lever	1	158748-0-01		40	Link Stud	1	156956-0-01	
32-2-1	Level Feed Connecting Rod	1	148496-0-00	F-32-2 Level Feed Connecting Rod Assembly 148801-0-01	41	Screw 4.37	1	151602-0-01	
32-2-2	Needle Bearing	1	118954-0-00						
32-2-3	Level Feed Connecting Link	1	143613-0-01						

G. Quick reverse mechanism[-400A--700A]
 Umkehr[-400A--700A]
 Mécanisme de marche arrière rapide[-400A--700A]
 Mecanismo de inversión rápida[-400A--700A]

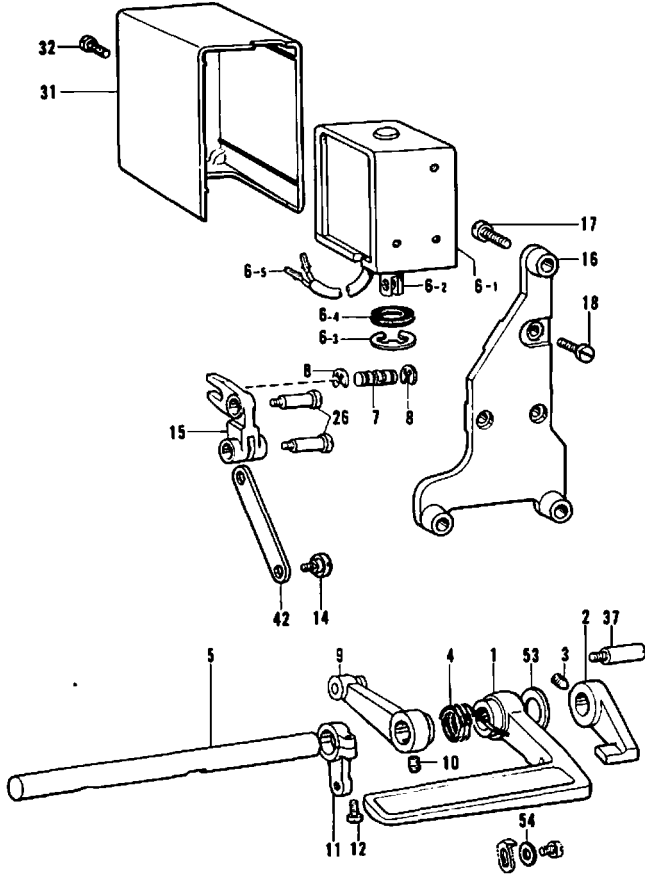

Ref. No.	Name of Parts	Q'ty	Parts No.	Assembly No.
1	Reverse Lever	1	156362-0-01	
2	Reverse Lever (B)	1	148607-0-02	
3	Screw 6.35 x 10	1	015771-0-12	
4	Spring	1	148608-0-01	
5	Reverse Lever Shaft	1	159429-0-01	
6-1	Solenoid	1		G-6 Reverse Solenoid Assembly (for EFKA Motor) 154734-0-01 (for Brother Motor) 159902-0-01
6-2	Plunger	1	154729-0-01	
6-3	Stop Ring E15	1	154730-0-01	
6-4	Rubber Stopper	1	154731-0-00	
6-5	Terminal Pin (for Brother Motor)	2	143549-0-00	
7	Pin	1	149174-0-01	
8	Stop Ring E4	2	048040-3-42	
9	Feed Regulator Link	1	148638-0-01	
10	Screw 5.95 x 6	1	014760-6-22	
11	Reverse Lever Shaft Arm	1	148640-0-01	
12	Screw 4.76-32 x 14	1	062711-4-12	
14	Stud Screw 4.76	1	110171-0-01	
15	Reverse Crank	1	158753-0-01	
16	Reverse Solenoid Bracket (for-400A)	1	158752-0-01	
17	Screw 6.35-28 x 25 (for-400A)	3	062782-5-12	
18	Screw 5 x 8	3	007500-8-02	
26	Stud Screw 4.76	2	148764-0-01	
31	Solenoid Cover (for-400A)	1	146105-0-00	
32	Screw 5 x 6 (for-400A)	1	007500-6-02	
37	Screw	1	141748-0-01	
42	Reverse Link	1	149063-0-01	
53	Thrust Ring	1	149554-0-01	
54	Washer	1	100645-0-03	

H. Feed shaft mechanism
 Transport welle
 Mécanisme de l'arbre entraînement
 Mecanismo de la eje alimentación

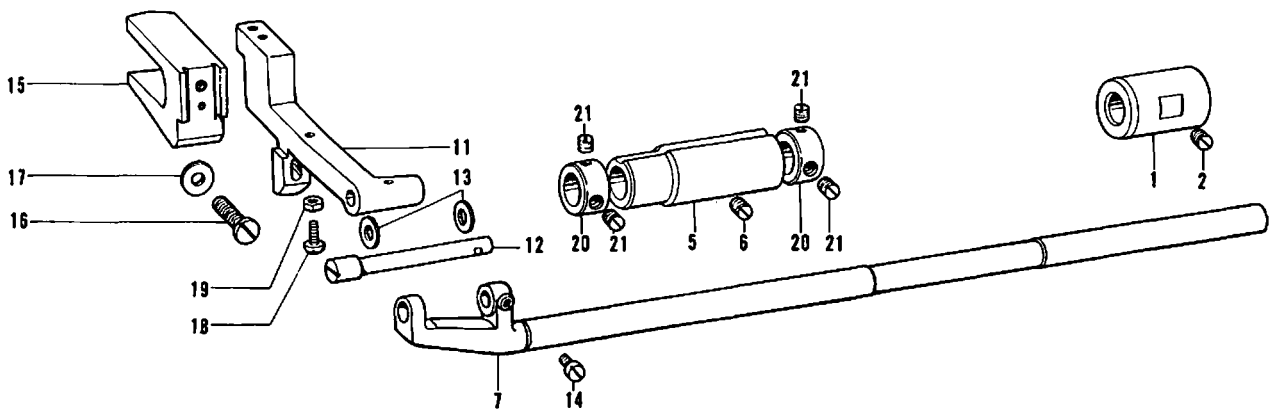

Ref. No.	Name of Parts	Q'ty	Parts No.	Assembly No.	Ref. No.	Name of Parts	Q'ty	Parts No.	Assembly No.
1	Feed Rock Shaft Bushing (Right)	1	148493-0-01		13	Thrust Ring	2	143591-0-01	
2	Screw 5.95	1	013761-4-10		14	Screw 4.37	1	104908-0-04	
5	Feed Rock Shaft Bushing (Left)	1	148494-0-01		15	Feed Bar Fork	1	112656-0-01	
6	Screw 5.95	1	013761-4-10		16	Screw 5.95-28 x 14	1	062761-4-12	
7	Feed Rock Shaft (for Standard)	1	149001-0-01		17	Washer 6	1	025060-1-32	
	Feed Rock Shaft (for Thread Trimmer)	1	148492-0-01		18	Screw 3.18-40 x 12	1	062661-2-12	
11	Feed Bar (for Standard)	1	151081-0-01		19	Nut 3.18	1	021660-1-02	
	Feed Bar (for Thread Trimmer)	1	148490-0-01		20	Collar	2	113074-0-01	
12	Feed Bar Shaft (for Standard)	1	148977-0-01		21	Screw 6.35	4	101706-0-01	
	Feed Bar Shaft (for Thread Trimmer)	1	148491-0-01						

J. Rotary hook mechanism (1)
 Greifervorrichtung (1)
 Mécanisme du crochet rotatif (1)
 Mecanismo del cangrejo (1)

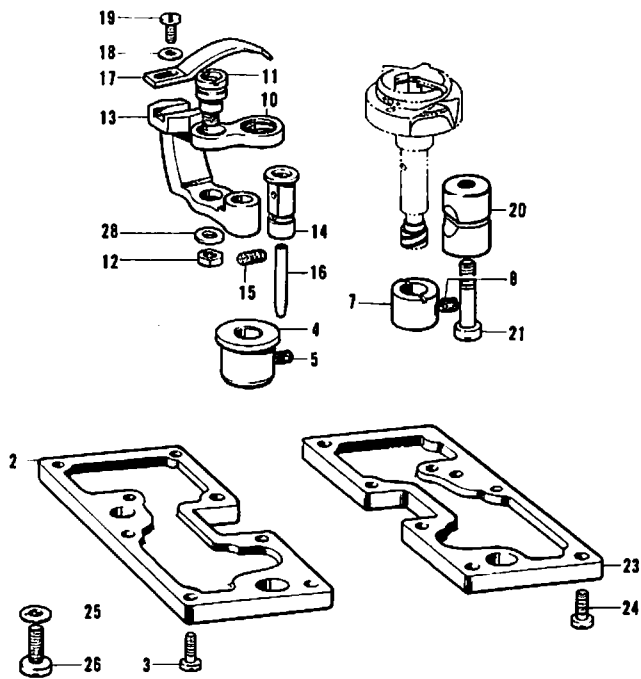

J. Rotary hook mechanism (2)(Standard)
 Greifervorrichtung (2)(Norm)
 Mécanisme du crochet rotatif (2)(Standard)
 Mecanismo del cangrejo (2)(Norma)

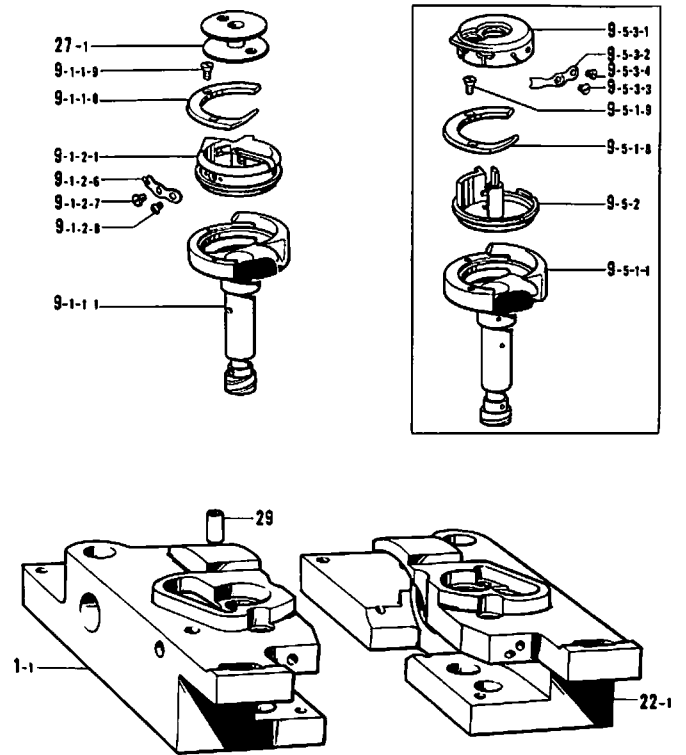

Ref. No.	Name of Parts	Q'ty	Parts No.	Assembly No.
2	Oil Reservoir (Left)	1	112686-0-01	
3	Screw 4.76	8	100320-0-02	
4	Rotary Hook Shaft Bushing (Lower)	2	112687-0-01	
5	Screw 4.76	2	107794-0-01	
7	Rotary Hook Shaft Bushing (Upper)	2	112690-0-01	
8	Screw 4.76	2	107794-0-01	
10	Opener Link	2	112692-0-01	
11	Link Stud Opener	2	148005-0-01	
12	Nut 4.76	2	110161-0-06	
13	Opener Crank	2	112694-0-01	
14	Opener Crank Stud	2	112695-0-01	
15	Screw 4.76	2	153483-0-01	
16	Pipe	1	112696-0-00	
17	Bobbin Case Opener	2	112697-0-01	
18	Washer	2	105161-0-02	
19	Screw 357-40 x 8	2	062670-8-12	
20	Pinch Sleeve	2	112699-0-01	
21	Screw 5.95	2	112700-0-01	
23	Rotary Hook Base Oil Reservoir (Right)	1	112702-0-01	
24	Screw 4.76	8	100320-0-02	
25	Washer	2	100197-0-02	
26	Screw 6.35	2	105351-0-02	
28	Washer 4.76	2	025710-2-32	

Ref. No.	Name of Parts	Q'ty	Parts No.	Assembly No.
1-1	Rotary Hook Base (Left)	1	112685-0-01	
9-1-1-1	Outer Rotary Hook	2		J-9-1-1 Outer Rotary Hook Assembly (for-1, -3) 151132-0-01 (for-5) 159931-0-01
9-1-1-8	Inner Rotary Hook Presser	2		
9-1-1-9	Screw	4	151027-0-01	J-9-1 Rotary Hook Assembly (for-1, -3) 112691-0-01 (for-5) 144903-0-01
9-1-2-1	Inner Rotary Hook	2		
9-1-2-6	Tension Adjusting Spring (for-1, -3)	2	151145-0-01	
9-1-2-6	Tension Adjusting Spring (for-5)	2	151146-0-01	
9-1-2-7	Tension Adjusting Screw	2	151029-0-01	J-9-1-2 Inner Rotary Hook Assembly (for-1, -3) 151138-0-01 (for-5) 151139-0-01
9-1-2-8	Screw	2	151030-0-01	
9-5-1-1	Outer Rotary Hook	2		J-9-5-1 Outer Rotary Hook Assembly 154515-0-01
9-5-1-8	Inner Rotary Hook Presser	2		
9-5-1-9	Screw	4	151027-0-01	
9-5-2	Inner Rotary Hook Assembly	2	154516-0-01	J-9-5 Rotary Hook Assembly 154327-0-01
9-5-3-1	Cap	2		
9-5-3-2	Tension Adjusting Spring	2	154518-0-01	J-9-5-3 Cap Assembly 159937-0-01
9-5-3-3	Tension Adjusting Screw	2	154519-0-01	
9-5-3-4	Screw	2	151030-0-01	
22-1	Rotary Hook Base (Right)	1	112701-0-01	
27-1	Bobbin	2	112781-0-01	
29	Oil Pipe	2	115287-0-00	

J. Rotary hook mechanism (3)[-400A--700A]
Greifervorrichtung (3)[-400A--700A]
Mécanisme du crochet rotatif (3)[-400A--700A]
Mécanismo del cangrejo (3)[-400A--700A]

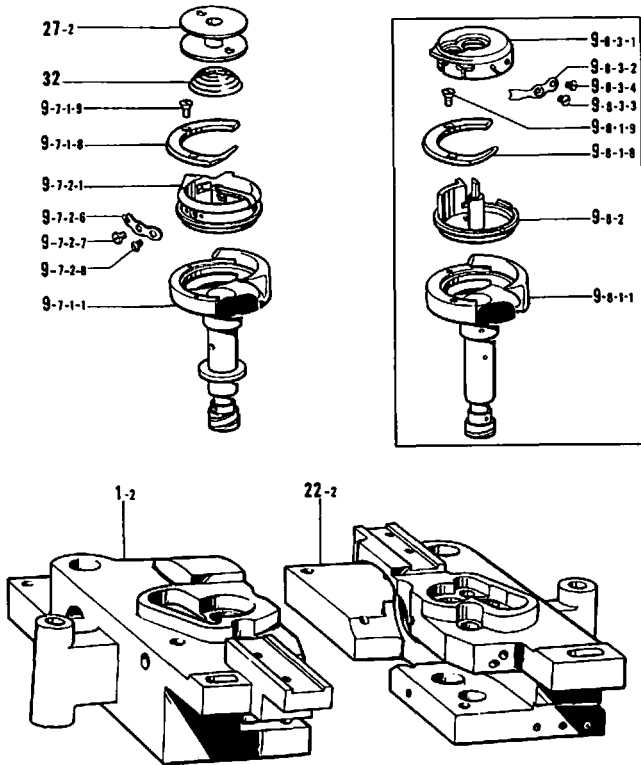

Ref. No.	Name of Parts	Q'ty	Parts No.	Assembly No.
1-2	Rotary Hook Base (Left)	1	148481-0-01	
9-7-1-1	Outer Rotary Hook	2		J-9-7-1 Outer Rotary Hook Assembly 159945-0-01
9-7-1-8	Inner Rotary Hook Presser	2		
9-7-1-9	Screw	4	151027-0-01	J-9-7 Rotary Hook Assembly 158760-0-01
9-7-2-1	Inner Rotary Hook	2		
9-7-2-6	Tension Adjusting Spring	2	151145-0-01	J-9-7-2 Inner Rotary Hook Assembly 159326-0-01
9-7-2-7	Tension Adjusting Screw	2	151029-0-01	
9-7-2-8	Screw	2	151030-0-01	
9-8-1-1	Outer Rotary Hook	2		J-9-8-1 Outer Rotary Hook Assembly S00881-0-01
9-8-1-8	Inner Rotary Hook Presser	2		
9-8-1-9	Screw	4	151027-0-01	
9-8-2	Inner Rotary Hook Assembly	2	159837-0-01	J-9-8 Rotary Hook Assembly 158762-0-01
9-8-3-1	Cap	2		J-9-8-3 Cap Assembly 159839-0-01
9-8-3-2	Tension Adjusting Spring	2	154518-0-01	
9-8-3-3	Tension Adjusting Screw	2	154519-0-01	
9-8-3-4	Screw	2	151030-0-01	
22-2	Rotary Hook Base (Right)	1	148480-0-01	
27-2	Bobbin	2	148603-0-01	
32	Bobbin Tension Spring	2	148601-0-01	
36	Specer 0.2		153243-0-01	
	Specer 0.3		153244-0-01	

K. Lower shaft mechanism / Untere welle
Mécanisme de l'arbre inférieur / Mécanismo de la eje inferior

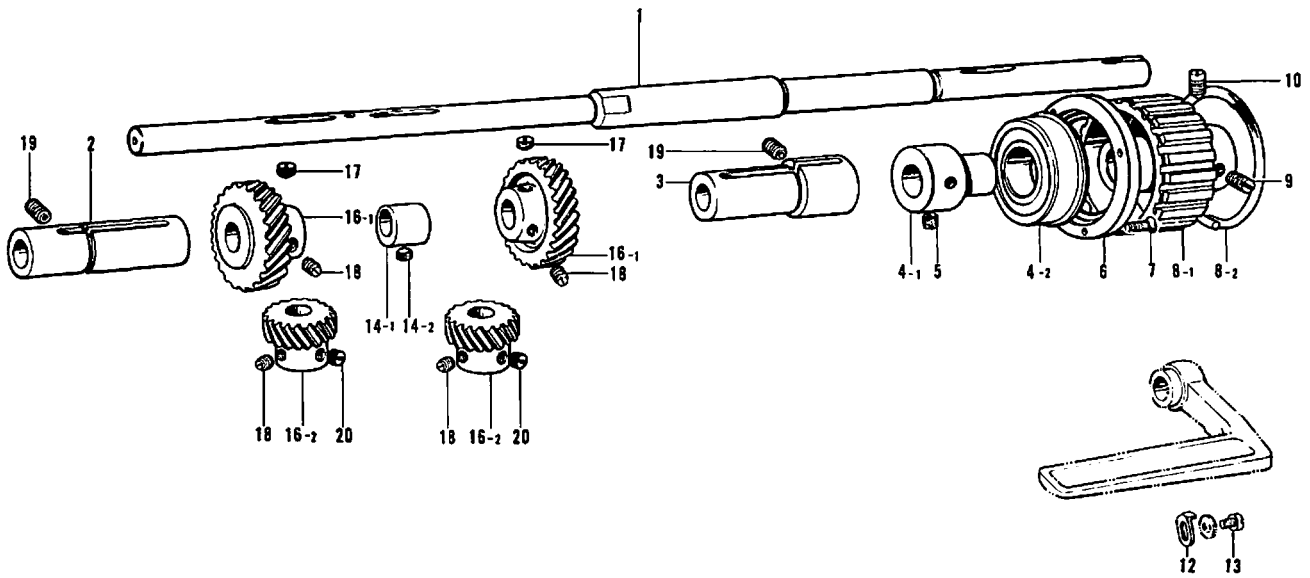

Ref. No.	Name of Parts	Q'ty	Parts No.	Assembly No.	Ref. No.	Name of Parts	Q'ty	Parts No.	Assembly No.
1	Lower Shaft (for Standard)	1	151082-0-01		10	Screw 6.35 x 12 (for Standard)	1	015771-2-12	
	Lower Shaft (for Thread Trimmer)	1	158750-0-01			Screw 6.35 (for Thread Trimmer)	1	148821-0-01	
2	Rotary Hook Base Bushing (Left)	1	148503-0-00		12	Reverse Lever Stopper	1	118865-0-01	
3	Rotary Hook Base Bushing (Right)	1	148502-0-00		13	Screw 437-40 x 7	1	062680-7-12	
4-1	Bearing Holder	1	112666-0-00	K-4 Bearing Holder Assembly 112668-0-01	14-1	Vertical Feed Eccentric Wheel	1		K-14 Vertical Feed Eccentric Wheel Assembly (for Standard) 181486-0-01 (for Thread Trimmer) 148804-0-01
4-2	Bushing	1	112667-0-01		14-2	Screw 6.35	1	112684-0-01	
5	Screw 6.35 x 7	2	013780-7-10		16-1	Spiral Gear	2		K-16 Spiral Gear Assembly 180949-0-01
6	Presser	1	112668-0-01		16-2	Pinion	2		
7	Screw 3.57 x 12	3	005671-2-12		17	Screw 6.35	2	112684-0-01	
8-1	Timing Belt Wheel Lower	1		K-8 Timing Belt Wheel Lower Assembly (for Standard) 180164-0-01 (for Thread Trimmer) 148803-0-01	18	Screw 6.35	4	100251-0-01	
8-2	Side Ring	1			19	Screw 5.95	2	151605-0-01	
9	Screw 6.35 x 12 (for Standard)	1	013771-2-12		20	Screw 6.35	6	101706-0-01	
	Screw 6.35 x 12 (for Thread Trimmer)	2	013771-2-12						

L. Lubrication (1) / Schmierung (1)
 Lubrification (1) / Lubricación (1)

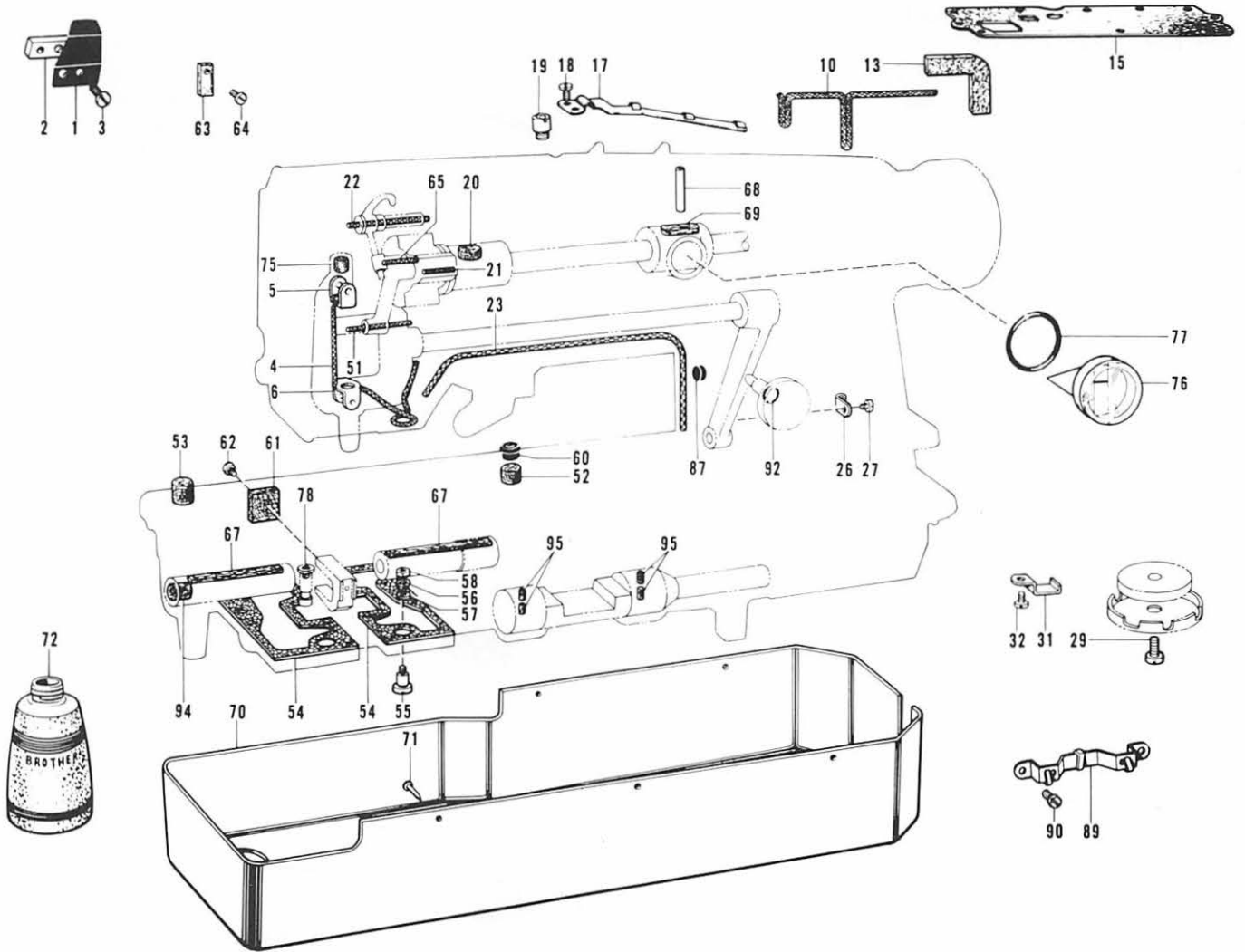

Ref. No.	Name of Parts	Q'ty	Parts No.	Assembly No.	Ref. No.	Name of Parts	Q'ty	Parts No.	Assembly No.
1	Oil Stopper Plate	1	112716-0-01		56	Spring Washer 2-4.37	2	028680-2-42	
2	Oil Stopper Plate Presser	1	112717-0-01		57	Washer	2	100645-0-03	
3	Screw 476-32 x 8	1	062710-8-12		58	Nut 4.37	2	105234-0-03	
4	Wick 4 x 4 (35 cm)	1	116699-0-00		60	Oil Cap	1	112758-0-01	
5	Felt Supporter (U)	1	112719-0-01		61	Felt	1	112759-0-01	
6	Felt Supporter (D)	1	112720-0-01		62	Screw 3.57	1	100242-0-03	
10	Wick 4 x 4 (25 cm)	1	112725-0-01		63	Felt	1	148762-0-01	
13	Felt	1	112724-0-01		64	Screw 3.57 x 6	1	001670-6-12	
15	Packing	1	112723-0-01		65	Wick 3 x 3 (3 cm)	1	114693-0-01	
17	Wick Holder	1	143657-0-01		67	Felt (Right)	2	113362-0-01	
18	Screw 3.18	2	106640-0-01		68	Pipe	1	112696-0-00	
19	Oil Guide Tube	1	113524-0-01		69	Felt	1	100248-0-01	
20	Felt	1	112734-0-01		70	Oil Pan	1	151007-1-01	
21	Wick 4 x 4 (12 cm)	1	112735-0-00		71	Nail	5	109714-0-00	
22	Wick 6 x 6 (10 cm)	1	112735-0-01		72	Oiler	1	114486-0-02	
23	Wick 4 x 4 (85 cm)	1	112736-0-00		75	Needle Bar Cap	1	148394-0-00	
26	Wick Supporter	1	112739-0-01		76	Oil Gauge Window	1	116558-0-01	
27	Screw 357-40 x 5	1	062670-5-12		77	Packing P16	1	081016-0-70	
29	Screw 476-32 x 10	1	062711-0-12		78	Felt	2	107155-0-01	
31	Felt Presser	2	114297-0-01		87	Cap	1	143766-0-01	
32	Screw 357-40 x 5	2	062670-5-12		89	Wick Support	1	143673-0-01	
51	Wick 4 x 4 (5 cm)	1	112728-0-01		90	Screw 318-40 x 4	2	062660-4-12	
52	Felt	1	112753-0-01		92	Packing	1	108549-0-01	
53	Felt	1	112754-0-01		94	Felt	1	115249-0-01	
54	Packing	2	112755-0-01		95	Felt	4	148743-0-01	
55	Oil Adjusting Screw	2	112756-0-01						

L. Lubrication (2)[Standard]
 Schmierung (2)[Norm]
 Lubrification (2)[Standard]
 Lubricación (2)[Norma]

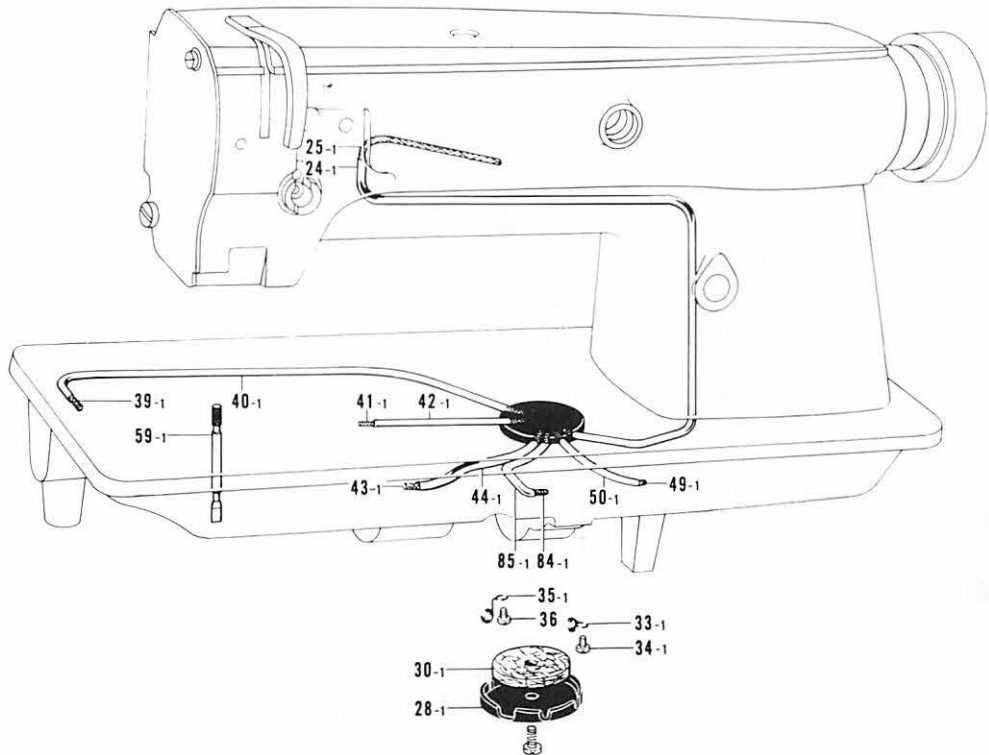
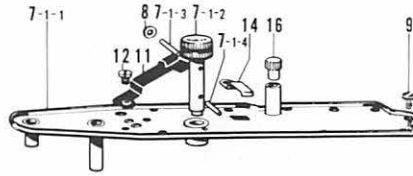
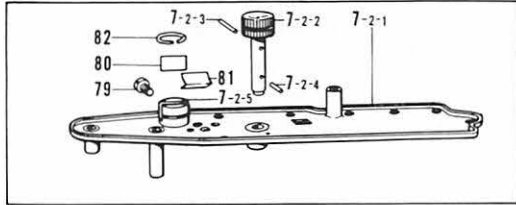

Ref. No.	Name of Parts	Q'ty	Parts No.	Assembly No.	Ref. No.	Name of Parts	Q'ty	Parts No.	Assembly No.
7-1-1	Oil Receiver Plate	1		L-7-1	33-1	Tube Holder	4	112743-0-01	
7-1-2	Oil Adjusting Knob	1		Oil Receiver	34-1	Screw 357-40 x 5	4	062670-5-12	
7-1-3	Pin	1		Plate Assembly	35-1	Tube Holder	2	112744-0-01	
7-1-4	Pin	1		(for -3, -5)	36-1	Screw 357-40 x 5	2	062670-5-12	
7-2-1	Oil Plate	1		112762-0-01	39-1	Wick 4 x 4 (33 cm)	1	143660-0-00	
7-2-2	Oil Adjusting Knob	1		L-7-2	40-1	Vinyl Tube	1	143661-0-00	
7-2-3	Pin	1		Oil Pan Plate	41-1	Wick 4 x 4 (40 cm)	1	143662-0-00	
7-2-4	Pin	1		Assembly	42-1	Oil Tube	1	151084-0-00	
7-2-5	Oil Plate Bushing	1		(for -1)	43-1	Wick 4 x 4 (15 cm)	1	143668-0-00	
8	Washer	1	503093-0-01	117200-0-01	44-1	Oil Tube	1	143669-0-00	
9	Screw 357-40 x 6	10	062670-6-12		49-1	Wick 4 x 4 (45 cm)	1	143670-0-00	
11	Spring Plate	1	112730-0-01		50-1	Oil Tube	1	143671-0-00	
12	Screw 357-40 x 4	1	062670-4-12		59-1	Oil Gauge	2	112757-0-01	
14	Felt Presser	1	114297-0-01		79	Screw 357-40 x 10	1	062671-0-12	
16	Cap for Oil Inlet	1	113526-0-01		80	Wick Presser Plate	1	117203-0-01	
24-1	Oil Tube	1	112737-0-01		81	Presser Spring	1	117204-0-01	
25-1	Wick 4 x 4 (75 cm)	1	112738-0-00		82	Stop Ring	1	117205-0-01	
28-1	Oil Pipe Supporter	1	151083-0-01		84-1	Wick 4 x 4 (55 cm)	1	143668-0-00	
30-1	Oil Felt	1	112741-0-01		85-1	Oil Tube	1	143669-0-00	

- L. Lubrication (3)[-400A--700A]
 Schmierung (3)[-400A--700A]
 Lubrification (3)[-400A--700A]
 Lubricación (3)[-400A--700A]

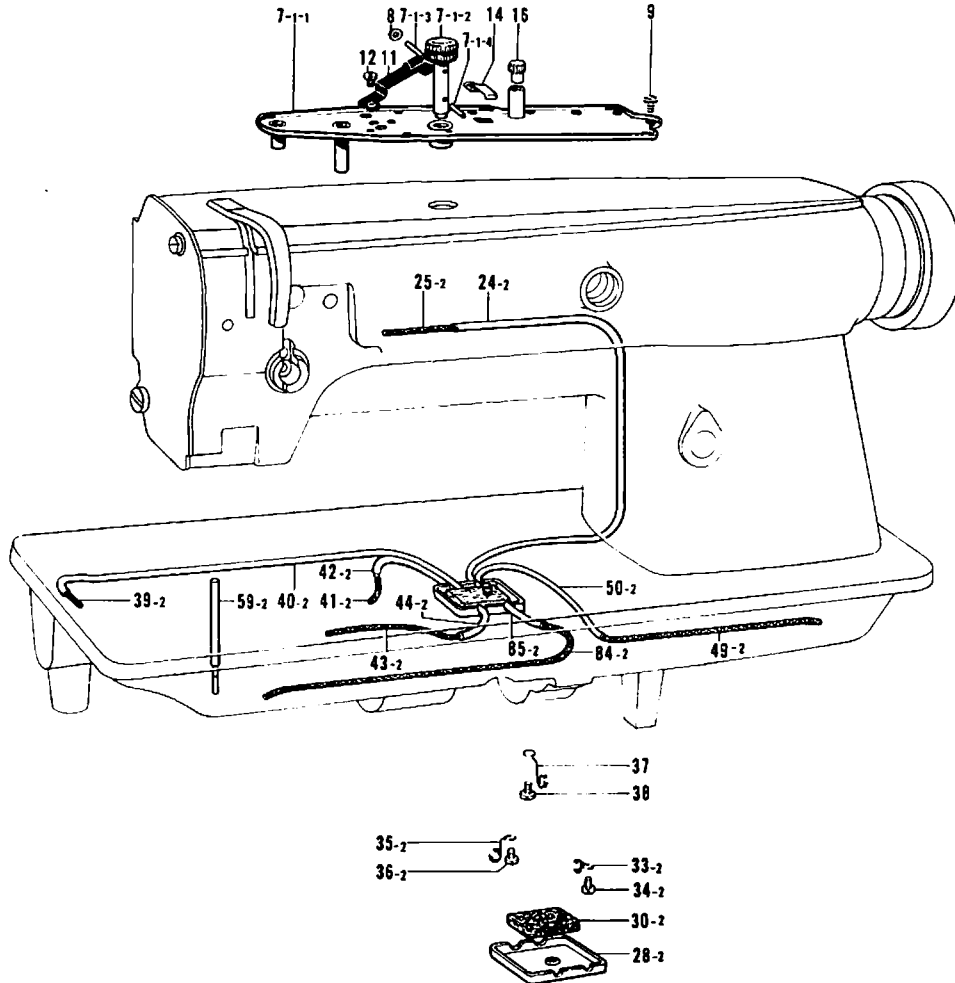

Ref. No.	Name of Parts	Q'ty	Parts No.	Assembly No.	Ref. No.	Name of Parts	Q'ty	Parts No.	Assembly No.
7-1-1	Oil Receiver Plate	1		L-7-1	35-2	Tube Holder	1	112744-0-01	
7-1-2	Oil Adjusting Knob	1		Oil Receiver Plate Assembly 112762-0-01	36-2	Screw 357-40 x 5	1	062670-5-12	
7-1-3	Pin	1			37	Wick Holder	1	112745-0-01	
7-1-4	Pin	1			38	Screw 357-40 x 5	1	062670-5-12	
8	Washer	1	503093-0-01		39-2	Wick 4 x 4 (35 cm)	1	148742-0-00	
9	Screw 357-40 x 6	10	062670-6-12		40-2	Oil Tube	1	148741-0-01	
11	Spring Plate	1	112730-0-01		41-2	Wick 4 x 4 (16 cm)	1	148740-0-00	
12	Screw 357-40 x 4	1	062670-4-12		42-2	Oil Tube	1	148733-0-01	
14	Felt Presser	1	114297-0-01		43-2	Wick 4 x 4 (30 cm)	1	148736-0-00	
16	Cap for Oil Inlet	1	113526-0-01		44-2	Oil Tube	1	148735-0-01	
24-2	Oil Tube	1	148730-0-01		49-2	Wick 4 x 4 (38 cm)	1	148734-0-00	
25-2	Wick 4 x 4 (80 cm)	1	148731-0-00		50-2	Oil Tube	1	148733-0-01	
28-2	Oil Tube Supporter	1	148729-0-01		59-2	Oil Gauge	2	148728-0-01	
30-2	Felt	1	148732-0-01		84-2	Wick 4 x 4 (53 cm)	1	148738-0-00	
33-2	Tube Holder	3	112743-0-01		85-2	Oil Tube	1	148737-0-01	
34-2	Screw 357-40 x 5	3	062670-5-12						

M. Thread wiper mechanism [-400A--700A]
 Fadenwischvorrichtung [-400A--700A]
 Mécanisme de tire-fil [-400A--700A]
 Mécansmo de limpiador de hilos [-400A--700A]

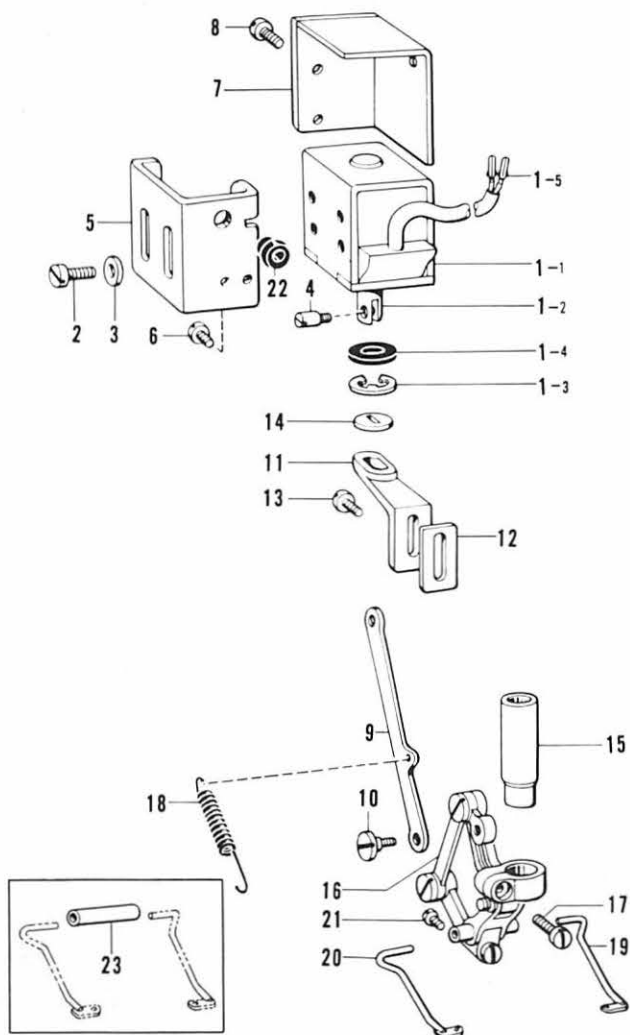

Ref. No.	Name of Parts	Q'ty	Parts No.	Assembly No.
1-1	Solenoid	1		M-1
1-2	Plunger	1	148511-0-01	Thread Wiper Solenoid
1-3	Stop Ring	1	048090-3-42	(for EFKA Motor)
1-4	Rubber Stopper	1	148512-0-00	156546-0-01
1-5	Terminal Pin (for Brother Motor)	2	143549-0-00	(for Brother Motor)
2	Screw 4 x 10	4	007401-0-12	159898-0-01
3	Washer 4	4	025040-2-32	
4	Plunger Pin	1	148546-0-01	
5	Solenoid Bracket	1	148513-0-02	
6	Screw 4.37	2	107407-0-03	
7	Solenoid Cover	1	148514-0-02	
8	Screw 357-40 x 4	3	062670-4-12	
9	Solenoid Link	1	148515-0-01	
10	Stud Screw 3.18	1	148521-0-01	
11	Stopper	1	148516-0-01	
12	Cork	1	148517-0-00	
13	Screw 4.37	2	107407-0-03	
14	Rubber Stopper	1	148518-0-00	
15	Presser Bar Bushing (Lower)	1	148508-0-01	
16	Thread Wiper Link	1	148770-1-01	
17	Screw 476-32 x 14	1	062711-4-12	
18	Spring	1	148527-0-01	
19	Thread Wiper (Right)	1	148529-0-01	
20	Thread Wiper (Left)	1	148530-0-01	
21	Screw	2	149177-0-01	
22	Bushing	1	146080-0-00	
23	Thread Wiper Holder (1/8~3/8)	1	148528-0-01	
	Thread Wiper Holder (L)(5/8)	1	149986-0-01	

N. Quick reverse switch mechanism [-400A--700A]
 Umkehrschalter [-400A--700A]
 Mécanisme de interrupteur de marche arrière rapide [-400A--700A]
 Mécansmo de conmutador de inversión rápida [-400A--700A]

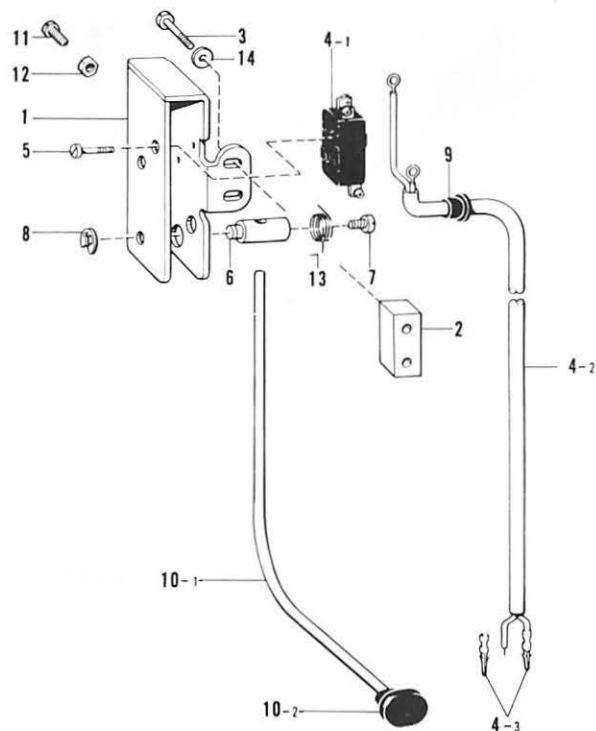

Ref. No.	Name of Parts	Q'ty	Parts No.	Assembly No.
1	Micro Switch Base	1	156997-0-01	
2	Spacer	1	149873-0-01	
3	Screw 3.57	2	120311-0-02	
4-1	Micro Switch	1	140643-0-00	N-4
4-2	Reverse Cord	1		Reverse Switch Assembly
4-3	Terminal Pin (for Brother Motor)	2	143549-0-00	(for Brother Motor)
5	Screw 2.38	2	146124-0-01	159896-0-00
6	Actuator Shaft	1	156998-0-01	(for EFKA Motor)
7	Screw 437-40 x 10	1	062681-0-12	156548-0-01
8	Stop Ring E4	1	048040-3-42	
9	Bushing	1	146080-0-00	
10-1	Actuator Bar	1		N-10
10-2	Push Button	1	156479-0-00	Actuator Assembly
11	Screw 437-40 x 14	1	062681-4-12	159350-0-01
12	Nut 4.37	1	102571-0-03	
13	Spring	1	157999-0-01	
14	Washer	2	105161-0-03	

P. Thread trimmer mechanism [-400A-700A] / Fadenabschneidevorrichtung [-400A-700A]
 Mécánisme de coupe-fill [-400A-700A] / Mécánismo de recortadora de orillos [-400A-700A]

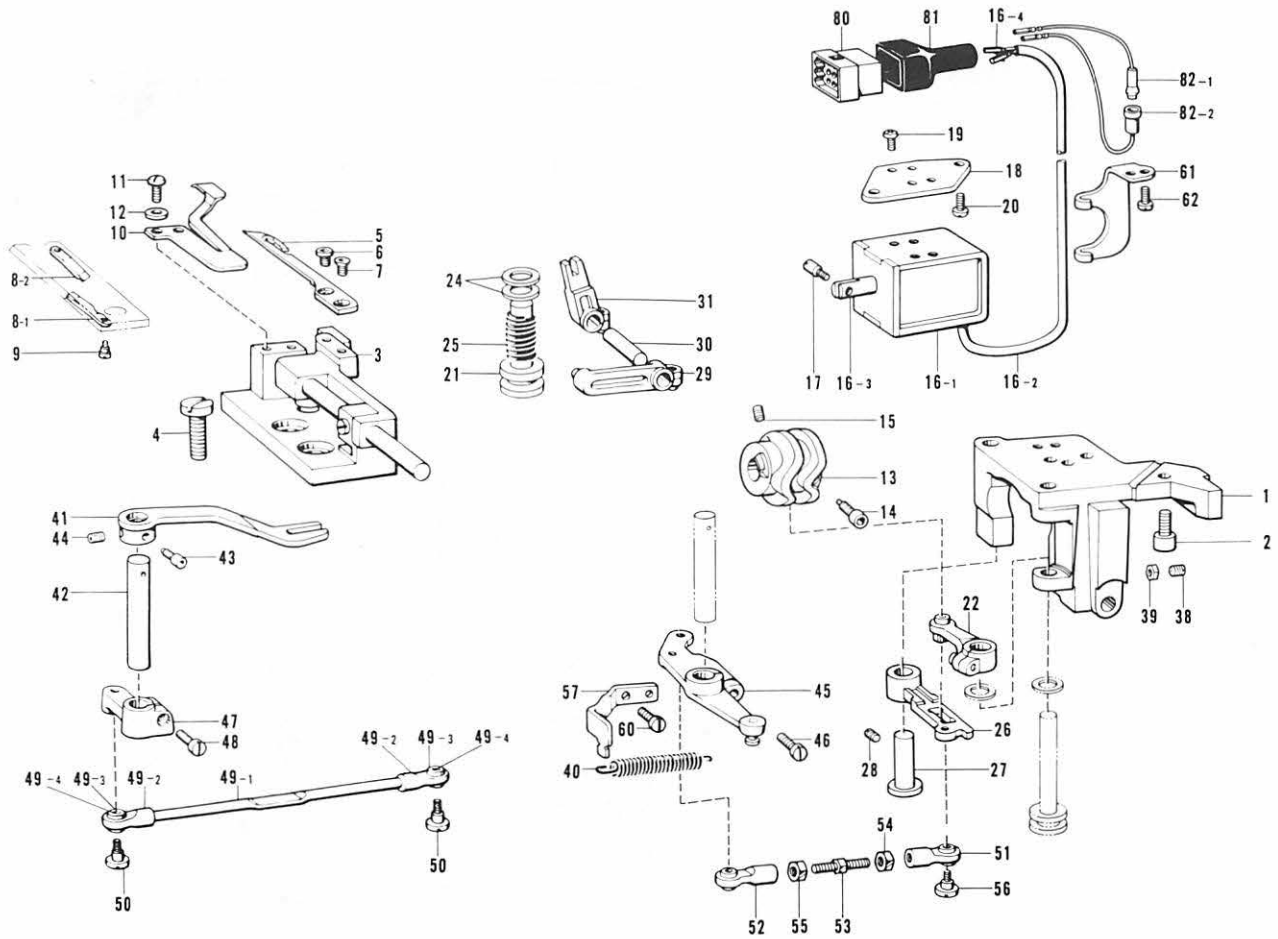

Ref. No.	Name of Parts	Q'ty	Parts No.	Assembly No.	Ref. No.	Name of Parts	Q'ty	Parts No.	Assembly No.
1	Movable Knife Base Bracket	1	148482-1-01		30	Knife Driving Lever Shaft 6.35 x 27	1	148557-0-01	
2	Bolt 6 x 16	3	018061-6-22		31	Knife Driving	1	181713-0-01	
3	Movable Knife Base Assembly	2	159362-0-01		38	Screw 7.14	1	011802-0-12	
4	Screw 476-32 x 8	4	062710-8-12		39	Nut 7.14	1	100078-0-03	
5	Movable Knife	2	159365-0-01		40	Spring	1	143609-0-01	
6	Screw 4.37	2	148536-0-01		41	Knife Rock Arm	2	159366-0-01	
7	Screw 4.37	2	148537-0-01		42	Knife Rock Arm Shaft	2	148573-0-01	
8-1	Fixed Knife (Left)	1	148538-0-01		43	Screw 6.35	2	148574-0-01	
8-2	Fixed Knife (Right)	1	149169-0-01		44	Screw 6.35 x 6	2	014770-6-22	
9	Stud Screw 2.38	2	148539-0-01		45	Knife Rock Lever Right Assembly	1	148575-0-01	
10	Thread Presser Spring (for -3)	2	148593-0-00		46	Screw 476-32 x 14	1	062711-4-12	
	Thread Presser Spring (for -5)	2	148594-0-00		47	Knife Rock Lever (Left)	1	158751-0-01	
11	Screw 2.38 x 4	4	001630-4-02		48	Screw 476-32 x 14	1	062711-4-12	
12	Washer 2.38	4	025630-1-32		49-1	Knife Connecting Bar	1		P-49 Connecting Rod Assembly **
13	Knife Driving Cam	1	158772-0-01		49-2	Joint	2	148584-0-01	
14	Screw 6.35	1	148574-0-01		49-3	Bushing	2		
15	Screw 6.35 x 6	1	014770-6-22		49-4	Spring Pin AW2	2		
16-1	Thread Trimmer	1		P-16 Thread Trimmer Solenoid (for EFKA Motor) 156550-0-01 (for Brother Motor) 159900-0-01	50	Screw	2	141494-0-01	
16-2	Solenoid Cord	1			51	Joint Assembly (Right)	1	148587-0-01	
16-3	Plunger	1	148545-0-01		52	Joint Assembly (Left)	1	148589-0-01	
16-4	Terminal Pin (for Brother Motor)	2	143549-0-00		53	Connecting Screw	1	148591-0-01	
17	Pin	1	148546-0-01		54	Nut 5.95	1	148592-0-01	
18	Solenoid Bracket	1	148561-1-01		55	Nut 5.95	1	100022-0-05	
19	Screw 4 x 8	4	002400-8-03		56	Screw	2	141494-0-01	
20	Screw 476-32 x 10	2	062711-0-12		57	Spring Hook (Right)	1	148579-0-01	
21	Knife Main Lever Shaft	1	148547-0-01		60	Screw 476-32 x 10	2	062711-0-12	
22	Knife Main Lever	1	148548-0-01		61	Cord Supporter	1	148655-0-01	
24	Rubber	2	148559-0-00		62	Screw 476-32 x 8	2	062710-8-12	
25	Spring	1	148555-0-01		80	Nylon Connector 12P (for Brother Motor)	1	153969-0-00	
26	Knife Sub Lever	1	158814-0-01		81	Connector Cap 5 (for Brother Motor)	1	153971-0-01	
27	Knife Sub Lever Shaft	1	148554-0-01		82-1	Cord (R)	1	S00897-0-00	P-82 Cord Assembly (for Brother Motor) S00896-0-00
28	Screw 5.95	1	100289-0-03		82-2	Cord (P)	1	S00899-0-00	
29	Knife Driving Pin Lever	1	181712-0-01						

Ⓞ If there is a "*" mark in the part code column or assembly code column, refer to the gauge assembly guide on page 22, 23.

Ⓞ Falls in den Kolonnen für Teilcode und Satzcode das Zeichen "*" steht, wird auf die Zusammenstellung der Vorrichtungen auf Seite 22, 23 verwiesen.

Ⓞ Si le signe apparaît dans la colonne du code des pièces ou dans celle du code d'assemblage, se reporter à la page 22, 23 du guide de montage de la jauge.

Ⓞ Si aparece una marca "*" en la columna de código de piezas o en la columna de código de armado, consultar la guía de armado de galga en la página 22, 23.

Q. Tension release mechanism [-400A--700A] / Spannung sverminderung svorrichtung [-400A--700A]
 Mécanisme de relâche-tension [-400A--700A] / Mecanismo de liberador de tensión [-400A--700A]

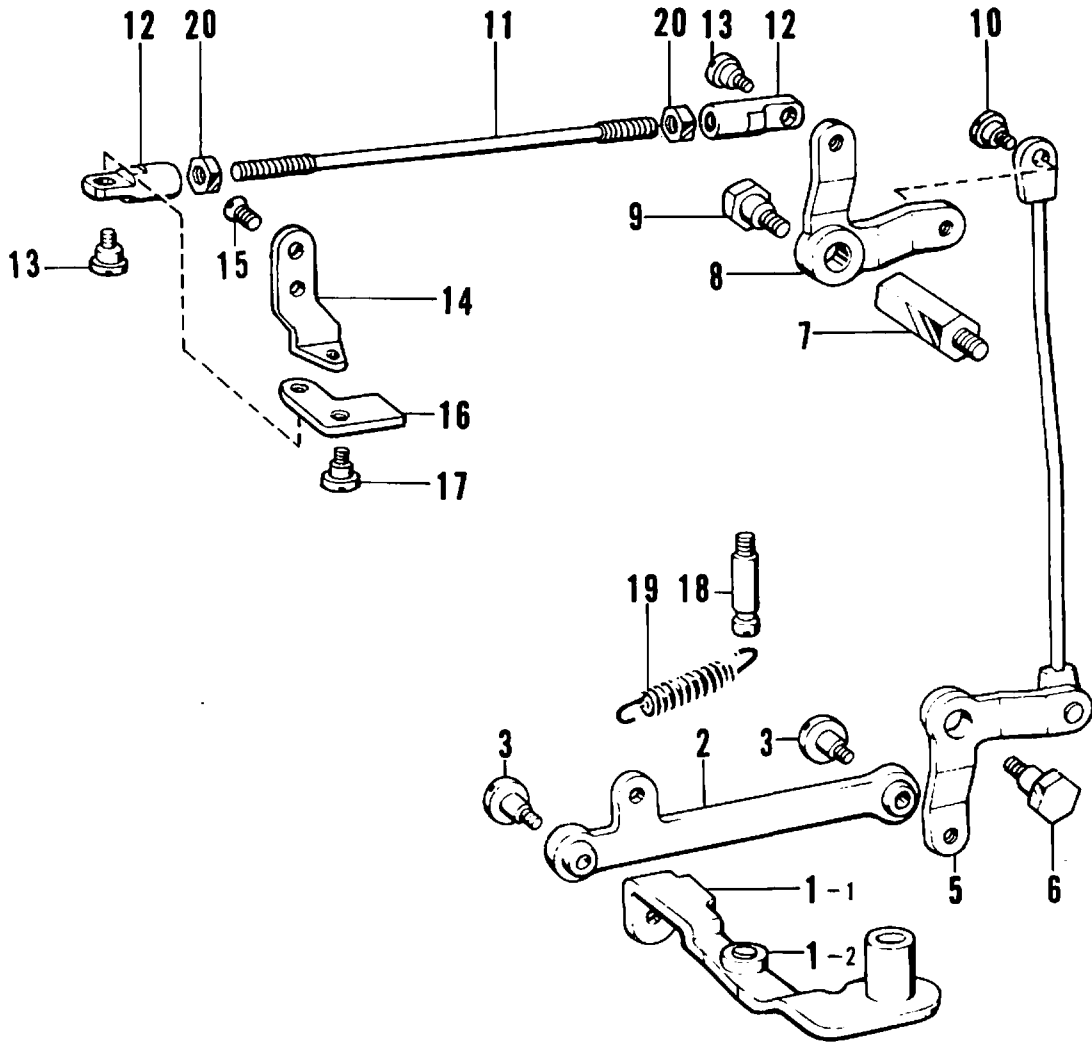

Ref. No.	Name of Parts	Q'ty	Parts No.	Assembly No.	Ref. No.	Name of Parts	Q'ty	Parts No.	Assembly No.
1-1	Tension Release Rock Lever	1		Q-1 Tension Release Rock Lever Assembly 148619-0-01	11	Tension Release Rod Upper	1	148631-0-01	
1-2	Tension Release Roller Stud	1			12	Joint	2	148632-0-01	
2	Tension Release Connecting Rod Lower	1	148623-0-01		13	Screw	2	148768-0-01	
3	Stud Screw 4.37	2	123882-0-01		14	Tension Release Plate	1	148634-0-01	
5	Tension Release Crank Lower	1	148625-0-01		15	Screw 4.37	2	117160-0-01	
6	Stud Screw 6.35	1	148628-0-01		16	Tension Release Crank	1	148635-0-01	
7	Stud	1	148629-0-01		17	Stud Screw 3.57	1	148633-0-01	
8	Tension Release Crank Upper	1	148630-0-01		18	Spring Hook	1	115177-0-01	
9	Stud Screw 6.35	1	148628-0-01		19	Spring	1	148654-0-01	
10	Stud Screw 4.76	1	110171-0-01		20	Nut 3.57	2	021670-1-02	

**R. Synchronizer (1)[-400A.-700A]
Synchronisator (1)[-400A.-700A]
Synchronisateur (1)[-400A.-700A]
Sincronizador (1)[-400A.-700A]**

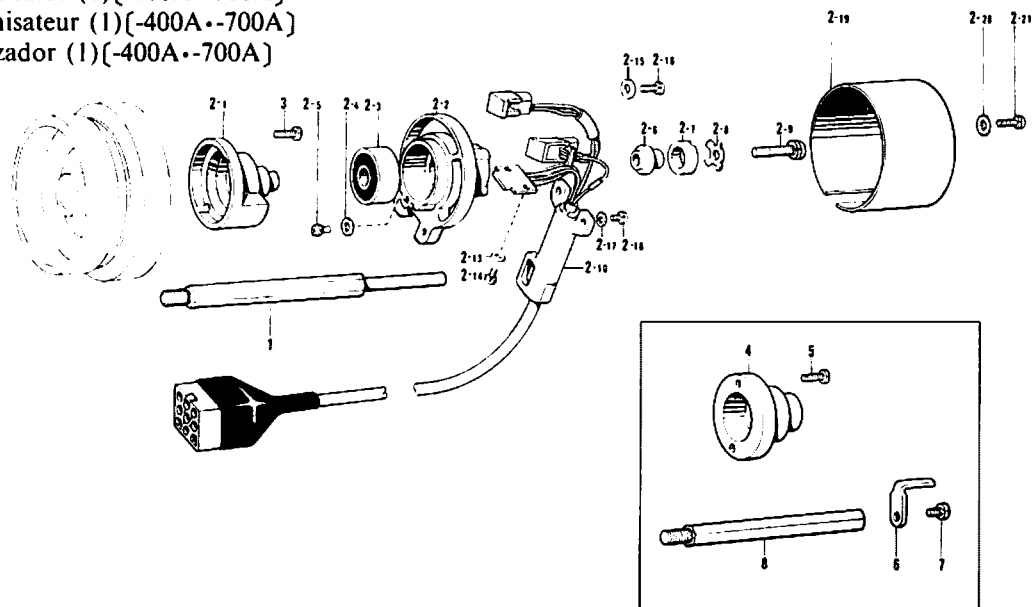

Ref. No.	Name of Parts	Q'ty	Parts No.	Assembly No.	Nef. No.	Name of Parts	Q'ty	Parts No.	Assembly No.
1	Synchronizer Holder Stud	1	148615-0-01	R-2 Synchronizer Assembly #10-2 (for Brother Motor) 224357-0-01	2-15	Washer 4	2	025040-3-35	R-2 Synchronizer Assembly #10-2 (for Brother Motor) 224357-0-01
2- 1	Magnet Stud	1			2-16	Screw 4 x 12D	2	217093-0-01	
2- 2	Synchronizer Holder #3	1			2-17	Washer 4	2	025040-1-35	
2- 3	Ball Bearing 6201VV	1			2-18	Screw 4 x 12D	2	217093-0-01	
2- 4	Washer 3	1	025030-3-35		2-19	Synchronizer Cover #4	1		
2- 5	Screw 3 x 6D	1	215083-0-01		2-20	Washer 4	2	025040-3-35	
2- 6	Magnet Setting Bracket	1	219557-0-00		2-21	Screw 4 x 12D	2	217093-0-01	
2- 7	Magnet 12 x 18.7 x 6	1	219558-0-00		3	Screw 476-32 x 14	2	062711-4-12	
2- 8	Magnet Holder Plate	1	219559-0-00		4	Slip Ring Support (for EFKA Motor)	1	148825-0-01	
2-19	Screw 6 x 25D	1	221421-0-01		5	Screw 476-32 x 14 (for EFKA Motor)	2	062711-4-12	
2-10	Hole I.C with Cord #7	1			6	Synchronizer Holder (for EFKA Motor)	1	158775-0-01	
2-13	Washer 3	2	025030-1-35		7	Screw 437-40 x 7 (for EFKA Motor)	1	062680-7-12	
2-14	Screw 3 x 6D	2	215083-0-01		8	Synchronizer Holder Stud (for EFKA Motor)	1	158776-0-01	

**S. Gauge parts mechanism / Lehren
Pièces d'écartement / Piezas calibradoras**

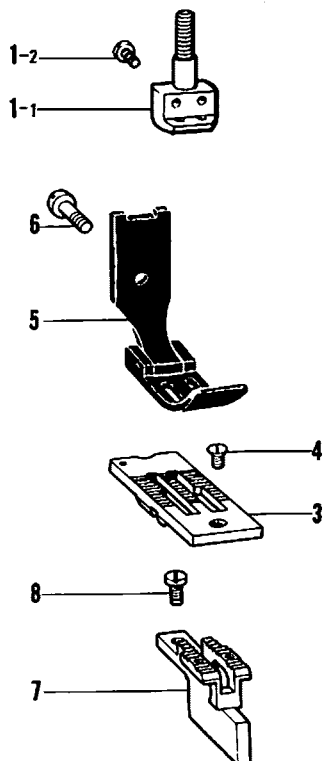

Ref. No.	Name of Parts	Q'ty	Parts No.	Assembly No.
1-1	Needle Clamp	2		S-1 Needle Clamp with Screw
1-2	Screw 3.57	2	116323-0-01	
3	Needle Plate (Assembly)	1	※	
4	Screw 4.37 (for -1)	1	100032-0-04	
	Screw 4.37 (for -3, -5)	1	117160-0-01	
5	Presser Foot	1	※	
6	Screw 3.57	1	113050-0-01	
7	Feed Dog	1	※	
8	Screw 3.18	2	116283-0-01	

◎ If there is a "※" mark in the part code column or assembly code column, refer to the gauge assembly guide on page 22, 23.

◎ Falls in den Kolonnen für Teilcode und Satzcode das Zeichen "※" steht, wird auf die Zusammenstellung der Vorrichtungen auf Seite 22, 23 verwiesen.

◎ Si le signe apparaît dans la colonne du code des pièces ou dans celle du code d'assemblage, se reporter à la page 22, 23 du guide de montage de la jauge.

◎ Si aparece una marca "※" en la columna de código de piezas o en la columna de código de armado, consultar la guía de armado de galga en la página 22, 23.

T. Control box mechanism (1)[-700A BROTHER Motor] / Schaltkasten (1)[-700A BROTHER Motor]
 Mécanisme du boîtier de contrôle (1)[-700A BROTHER Moteur] / Mecanismo del caja de controles (1)[-700A BROTHER Motor]

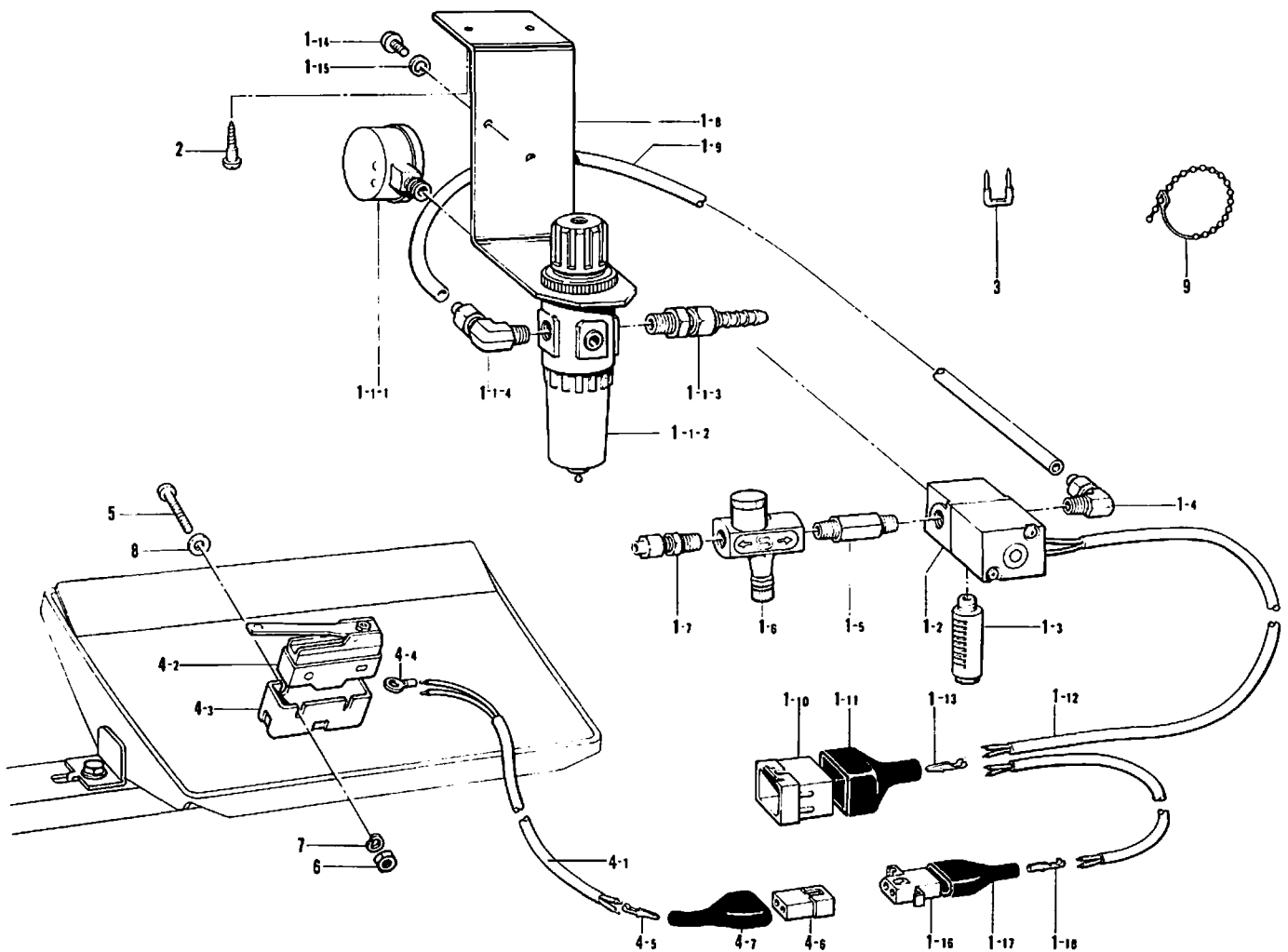

Ref. No.	Name of Parts	Q'ty	Parts No.	Assembly No.	Ref. No.	Name of Parts	Q'ty	Parts No.	Assembly No.
1- 1-1	Presser Gauge	1		T-1-1 Air Unit Assembly 151153-1-01	1-16	Nylon Connector	1	143499-0-00	T-1 Air Unit Valve Assembly 159813-0-01
1- 1-2	Valve	1	143960-1-01		1-17	Connector Cap	1	143489-0-01	
1- 1-3	Air Tube Connector	1	140678-0-00		1-18	Terminal Pin	2	143548-0-00	
1- 1-4	1/4 Elbow	1	140538-0-00		2	Screw 4.5 x 20	2	101118-0-01	T-4 Presser Foot Lifter Cord Assembly 146160-0-01
1- 2	Air Valve	1	159814-0-00		3	Staple	8	200190-0-01	
1- 3	Silencer	1	140682-0-01		4- 1	Presser Foot Lifter Cord	1		
1- 4	1/8 Elbow Assembly	1	151147-0-01		4- 2	Micro Switch	1	140948-0-01	
1- 5	Speed Control Connector	1	142037-0-00		4- 3	Cover	1	140950-0-00	
1- 6	Speed Controller	1	142038-0-01		4- 4	Terminal	2	140693-0-00	
1- 7	1/8 Connector	1	140543-0-00		4- 5	Terminal Pin	2	143549-0-00	
1- 8	Air Unit Holder Plate	1			4- 6	Nylon Connector	1	143488-0-01	
1- 9	Air Tube	1	140540-0-00		4- 7	Connector Cap	1	143489-0-01	
1-10	6P Nylon Connector	1	146118-0-00		5	Screw 3 x 30	2	002303-0-06	
1-11	Connector Cap	1	145596-0-01		6	Nut 3	2	021300-1-03	
1-12	Tube	1			7	Washer 2-3	2	028030-2-43	
1-13	Terminal Pin	2	143549-0-00	8	Washer 3	2	025030-2-33		
1-14	Screw 5 x 10	2	002501-0-03	9	Bead Band	1	144189-0-01		
1-15	Washer 2-5	2	028050-2-43						

U. Treadle mechanism (Option parts) / Pedal (Option parts)
 Mécanisme de la pédale (Pièces en option) / Mécanisme de la pedal (Piezas opción)

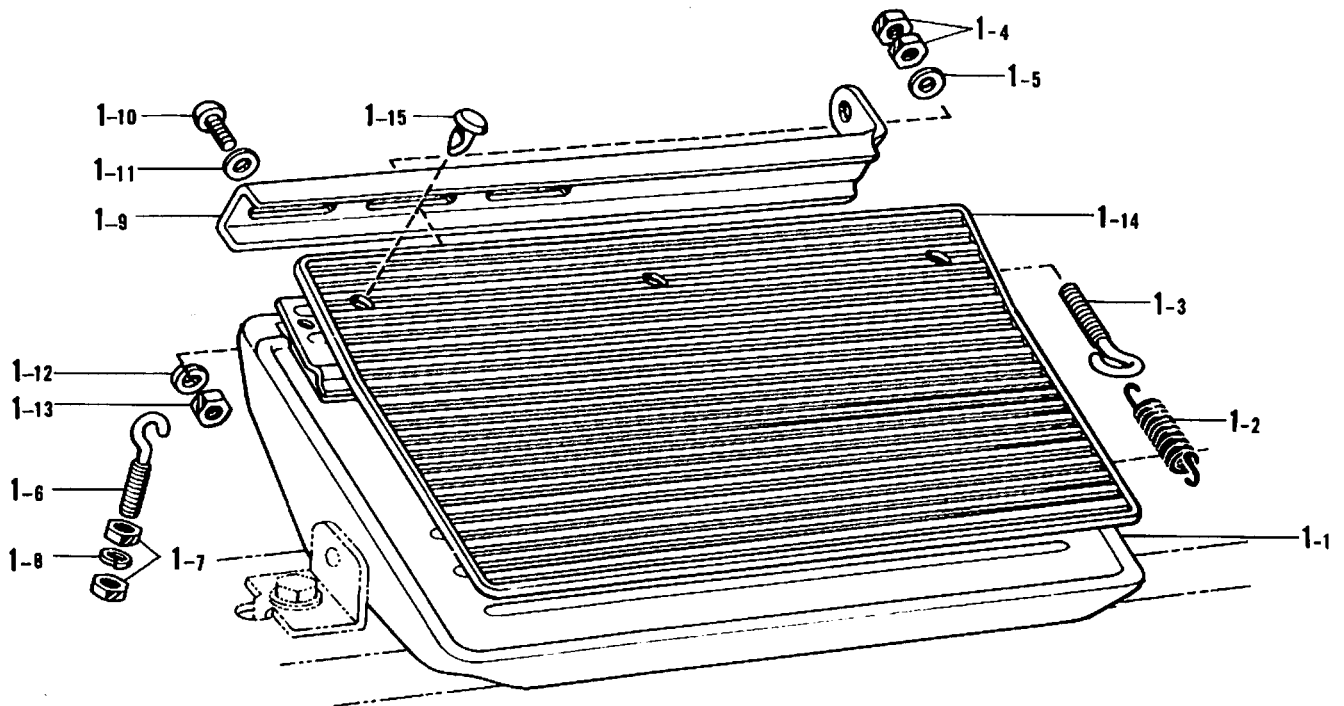

Ref. No.	Name of Parts	Q'ty	Parts No.	Assembly No.	Ref. No.	Name of Parts	Q'ty	Parts No.	Assembly No.
1- 1	Treadle	1		U-1 Treadle Assembly 146175-0-01	1- 9	Treadle Connector Arm	1		U-1 Treadle Assembly 146175-0-01
1- 2	Spring	1	146178-0-01		1-10	Screw 6 x 16	2	001061-6-06	
1- 3	Spring Hook	1	140953-0-01		1-11	Washer 6	2	025060-2-36	
1- 4	Nut 5	2	021500-1-04		1-12	Washer 2-6	2	028060-2-42	
1- 5	Washer 5	1	025050-2-33		1-13	Nut 6	2	021060-2-06	
1- 6	Adjusting Hook	1	140947-0-02		1-14	Rubber Cover	1	109268-0-01	
1- 7	Nut 4 x 5	2	212251-0-01		1-15	Clip 6	3	146358-0-01	
1- 8	Washer 2-4	1	028040-2-43						

Z. Accessories (1) / Zubehör (1)
 Accessoires (1) / Accesorios (1)

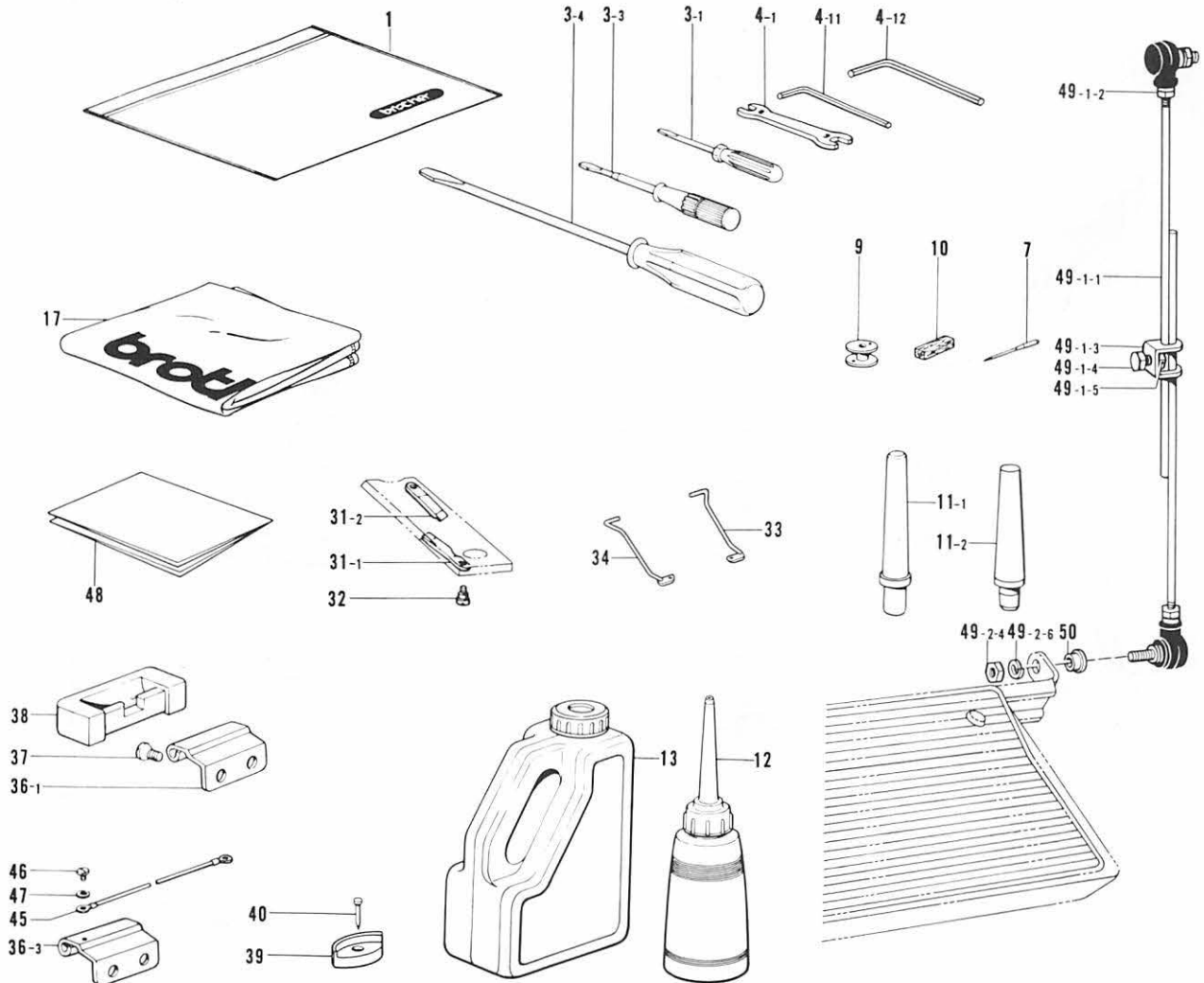

Ref. No.	Name of Parts	Q'ty	Parts No.	Assembly No.	Ref. No.	Name of Parts	Q'ty	Parts No.	Assembly No.
1	Vinyl Bag	1	122991-0-01		33	Thread Wiper (Right)(for Thread Trimmer)	1	148529-0-01	
3- 1	Screw Driver 1.9 x 52	1	142443-0-01		34	Thread Wiper (Left)(for Thread Trimmer)	1	148530-0-01	
3- 3	Screw Driver 3.4 x 70	1	118837-0-01		36- 1	Head Hinge (for Standard)	2	148882-0-01	
3- 4	Screw Driver 5.5 x 19	1	101572-1-01		36- 3	Head Hinge (for Thread Trimmer)	1	148882-0-01	
4- 1	Spanner 8 x 9	1	100887-0-01		37	Screw 6.35	4	112569-0-01	
4-11	Allen Wrench 2 (for Thread Trimmer)	1	142002-0-01		38	Rubber Hinge	2	143910-0-01	
4-12	Allen Wrench 3 (for Thread Trimmer)	1	142721-0-01		39	Head Cushion	4	148890-1-01	
7	Needle DP x 5 #11 (for-1)	8	107415-0-11		40	Nail	8	109714-0-00	
	Needle DP x 5 #14 (for-3)	8	107415-0-14		45	Earth Wire (for Thread Trimmer)	1	145946-0-01	
	Needle DP x 5 #21 (for-5)	8	107415-0-21		46	Screw 437-40 x 6 (for Thread Trimmer)	1	062680-6-16	
	Needle DP x 5 #22 (for-5)	8	107415-0-22		47	Washer 4.37 (for Thread Trimmer)	1	025680-1-33	
9	Bobbin (for Standard)	10	112781-0-01		48	Table Sheet	1	150381-0-01	
	Bobbin (for Thread Trimmer)	10	148603-0-01		49- 1-1	Connecting Rod	2		Z-49-1 Connecting Rod Assembly 119710-0-01
10	Felt (for Standard)	2	114941-0-01		49- 1-2	Nut 6	2	021060-1-06	
11- 1	Head Rest (for Standard)	1	100477-0-01		49- 1-3	Connecting Rod Holder	1		Z-49 Treadle Bar Assembly (Option Parts) 133797-0-01
11- 2	Head Rest (for Thread Trimmer)	1	149010-0-00		49- 1-4	Bolt 7.94-18	1		
12	Oiler	1	114483-0-02		49- 1-5	Nut 7.94-18	1		
13	Oil Tank	1	154702-0-01		49- 2-1	Joint	2		Z-49-2 Joint Assembly 133792-0-01
17	Head Cover	1	144222-0-01		49- 2-4	Nut 6	2	021060-1-06	
31- 1	Fixed Knife (Left)(for Thread Trimmer)	1	148538-0-01		49- 2-6	Washer 2-6	2	028060-2-43	
31- 2	Fixed Knife (Right)(for Thread Trimmer)	1	149169-0-01		50	Collar	2	114859-0-01	
32	Stud Screw 2.38 (for Thread Trimmer)	2	148539-0-01						

*The details of included accessories are subject to change.
 *Les détails des accessoires inclus sont sujets à des changements.

*Änderungen in der Aufstellung der mitgelieferten Zubehöre sind vorbehalten.
 *Los detalles de los accesorios incluidos pueden variar.

Z. Accessories (2) / Zubehör (2)
 Accessoires (2) / Accesorios (2)

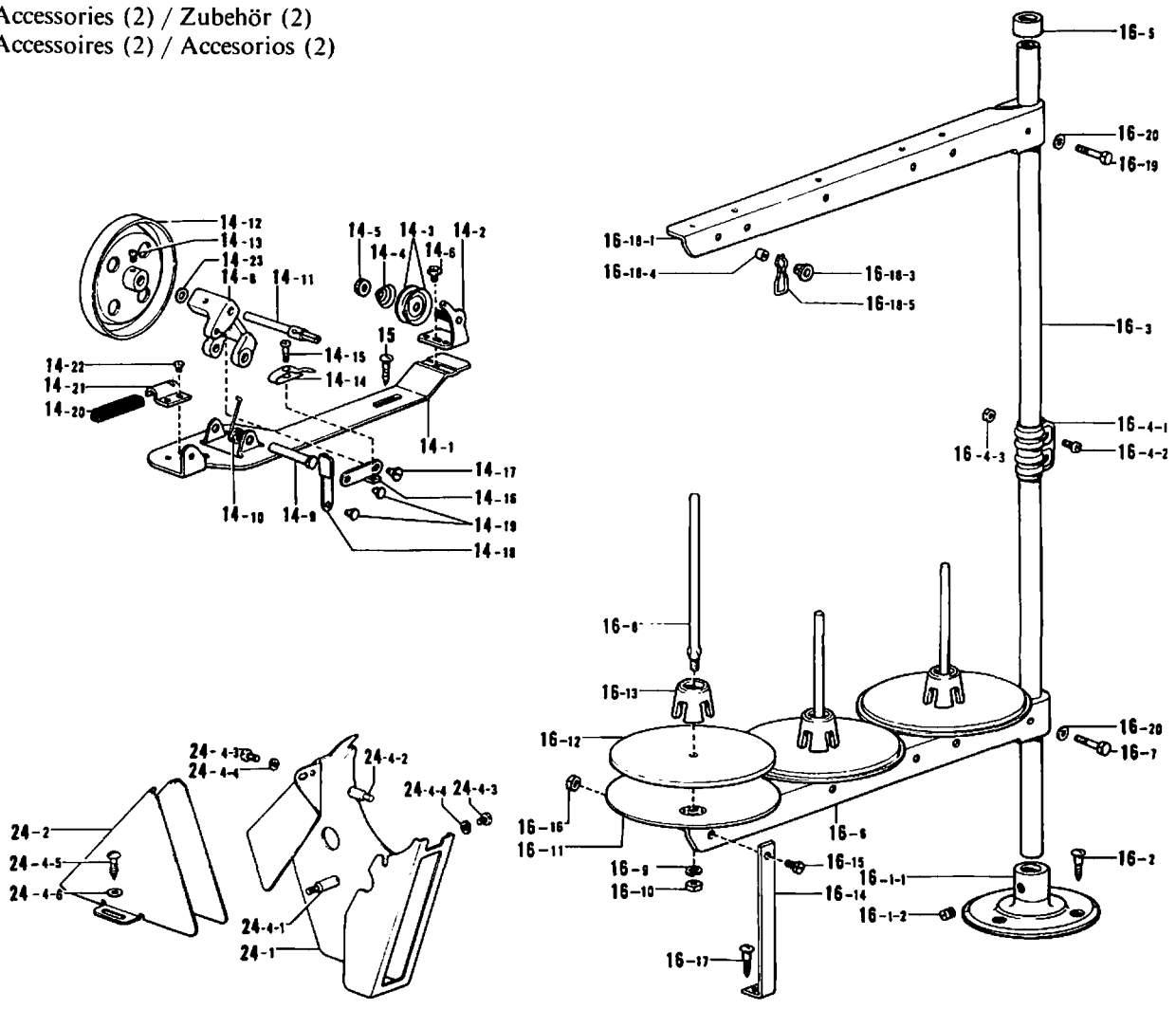

Ref. No.	Name of Parts	Qty	Parts No.	Assembly No.	Ref. No.	Name of Parts	Qty	Parts No.	Assembly No.
14- 1	Bobbin Winder Wheel Bracket	1		Z-14 Bobbin Winder Assembly 117963-0-01	16- 4-3	Nut 5	2	021500-1-03	Z-16-4 Joint for Cotton Stand 150106-0-01
14- 2	Bobbin Winder Guide Assembly	1			16- 5	Cap	1		
14- 3	Tension Disc	2	145446-0-01		16- 6	Spool Holder	1	150176-0-01	
14- 4	Tension Spring	1	100401-0-01		16- 7	Bolt 5 x 28	1	017502-8-03	
14- 5	Tension Control Nut	1			16- 8	Spool Shaft (B)	3	150179-0-01	
14- 6	Screw 4.37	1			16- 9	Spring Washer 2-5	3	028050-2-43	
14- 8	Bobbin Winder Wheel Shaft Supporter	1			16-10	Nut 5	3	021500-1-03	Z-16 Cotton Stand Assembly 3 150151-0-03
14- 9	Pin	1			16-11	Spool Stand Base	3	150180-0-00	
14-10	Spring	1	117969-0-01		16-12	Spool Mat	3	150182-0-00	
14-11	Bobbin Winder Shaft	1	117970-0-01		16-13	Spool Cushion	3	126863-0-00	
14-12	Bobbin Winder Wheel Assembly	1	117971-0-01		16-14	Spool Holder Supporter (A)	1	150188-0-01	
14-13	Screw 4.37 x 5	1	100366-0-02		16-15	Screw 5 x 10	1	007501-0-03	
14-14	Bobbin Presser	1			16-16	Nut 5	1	021500-1-03	
14-15	Screw 3.18	1	100657-0-01		16-17	Screw 4.5 x 22	1	031452-2-03	
14-16	Bobbin Presser Arm	1			16-18-1	Spool Holder	1	150176-0-01	Z-16-18 Thread Hanger Assembly 3 150193-0-03
14-17	Stud Screw 3.18	1	100659-0-01		16-18-3	Thread Hanger	3		
14-18	Bobbin Presser Bracket	1			16-18-4	Thread Bushing	3	142990-0-01	
14-19	Pin	2			16-18-5	Thread Guide Spring	3	150184-0-01	
14-20	Bobbin Winder Wheel Stopper	1	100662-0-01		16-19	Bolt 5 x 28	1	017502-8-03	
14-21	Bobbin Winder Wheel Stopper Holder	1			16-20	Washer 5	2	025050-2-33	
14-22	Screw 3.57 x 3.5	1	009679-3-12		24- 1	Belt Cover (UD)	1		Z-24 Belt Cover Complete(D) 147908-0-01
14-23	Washer	2			24- 2	Belt Cover (D)	1		
15	Screw 5.5 x 20	2	100666-0-02	24- 4-1	Belt Cover Stud (B)	1	147856-0-02		
16- 1-1	Cotton Stand Base	1		24- 4-2	Belt Cover Stud (D)	1	147858-0-01		
16- 1-2	Screw 6 x 7	2	150181-1-01	24- 4-3	Screw 437-40 x 8	2	062680-8-12		
16- 2	Screw 4.5 x 22	3	031452-2-03	24- 4-4	Spring Washer 2-4.37	2	028680-2-42		
16- 3	Pipe	2	150172-0-01	24- 4-5	Screw 5.5 x 20	2	100666-0-02		
16- 4-1	Joint	1		24- 4-6	Washer 5.56	2	025750-1-32		
16- 4-2	Screw 5 x 14	2	150202-0-01						

*The details of included accessories are subject to change.
 *Les détails des accessoires inclus sont sujets à des changements.

*Änderungen in der Aufstellung der mitgelieferten Zubehöre sind vorbehalten.
 *Los detalles de los accesorios incluidos pueden variar.

Gauge parts list (Standard) / Liste des pièces d'écartement (Standard)
 Lehren liste (Norm) / Lista de piezas calibradoras (Norma)

Gauge Size Lehre Taille de jauge Tamaño de galga	Sub class Untergruppe Sous-classe Subclase	Needle Clamp Nadelklammer Pince-aiguille Ménsula de aguja	Needle Plate Stichplatte Plateau à aiguille Placa de aguja	Feed Dog Transporteur Griffe d'entraînement Alimentador	Presser Foot Stoffdrückfuß Presseur Prensatelas	Slide Plate(Left) Deckel(Linke) Plaques de glissement(Gauche) Placas corredizas(Izquierda)
Tandem (0.5 mm)	- 3	158801-0-01	142111-0-01	142110-0-01	142105-0-01	112606-0-01
1/16 inch (1.6 mm)	- 3	158808-0-01	142111-0-01	151078-0-01	151076-0-01	
1/8 inch (3.2 mm)	- 1	158794-0-01	117370-0-01	117366-0-01	114948-0-01	
	- 3		114950-0-01	114951-0-01		
	- 5		117369-0-01			
5/32 inch (4.0 mm)	- 3	158796-0-01	116503-0-01	116509-0-01	116502-0-01	
	- 5		150850-0-01			
3/16 inch (4.8 mm)	- 1	158791-0-01	117158-0-01	117134-0-01	112638-0-01	
	- 3		112603-0-01	112659-0-01		
	- 5		117133-0-01			
1/4 inch (6.4 mm)	- 1	158792-0-01	117368-0-01	117365-0-01	112642-0-01	
	- 3		112604-0-01	112660-0-01		
	- 5		117367-0-01			
5/16 inch (7.9 mm)	- 3	158793-0-01	112605-0-01	112661-0-01	112645-0-01	
	- 5		144882-0-01			
3/8 inch (9.5 mm)	- 3	158798-0-01	116506-1-01	116510-1-01	116498-0-01	
	- 5		144881-1-01			
7/16 inch (11.1 mm)	- 3	158809-0-01	151596-0-01	151598-0-01	151597-0-01	
1/2 inch (12.7 mm)	- 3	158797-0-01	116505-0-01	116511-0-01	116499-0-01	
5/8 inch (15.9 mm)	- 5	158795-0-01	116507-0-01	116512-0-01	116500-0-01	
1-1/4 inch (31.8 mm)	- 3	158799-0-01	116504-0-01	116508-0-01	116501-0-01	145721-0-01
1-1/2 inch (38.1 mm)	- 3	158800-0-01	118945-0-01	118947-0-01	118946-0-01	
2 inch (50.8 mm)	- 5	158802-0-01	144951-0-01	144947-0-01	144949-0-01	150836-0-01
2-1/6 inch (55.0 mm)	- 5	158803-0-01	147560-0-01	147561-0-01	147562-0-01	

- ⊗ In case of using 2-1/6" (55 mm) gauge parts, it is required to make special machining on the arm-bed.
- ⊗ Falls die 2-1/6-Nadellehre (55 mm) verwendet wird, muß der Arm dazu speziell abgeändert werden.
- ⊗ Pour utiliser la jauge de 2-1/6" (55 mm), il est nécessaire de procéder à des modifications particulières sur le socle du bras.
- ⊗ Si se utiliza un calibrador de 2-1/6 pulg. (55 mm) se deberá realizar una preparación especial del brazo.

Presser Foot with Guide / Stoffdrückerfuß mit Führung Pied presseur avec guide / Pie del prensatelas con guía	
1/8 inch (3.2 mm)	149311-0-01
3/16 inch (4.8 mm)	117281-0-01
1/4 inch (6.4 mm)	149312-0-01



Gauge parts list (Thread trimmer) / Liste des pièces d'écartement (Coupe-fil)
 Lehren liste (Fadenabschneider) / Lista de piezas calibradoras (Cortahilos)

Gauge Size Lehre Taille de jauge Tamaño de galga	Sub class Untergruppe Sous-classe Subclase	Needle Clamp Nadelklammer Pince-aiguille Ménsula de aguja	Needle Plate Stichplatte Plateau à aiguille Placa de aguja	Feed Dog Transporteur Griffe d'entraînement Alimentador	Presser Foot Stoffdrückfuß Presseur Prensatelas	Connecting rod assembly Verbindungsstange kompl Bielle Cojuno de la varilla de conexión	Thread wiper guide Fadenwischerführung Guide de tire-fils Guía del retirador de hilos	
3/32 inch (2.4 mm)	-5	158804-0-01	159398-0-01	148697-0-01	148679-0-01	148581-0-01	148528-0-01	
1/8 inch (3.2 mm)	-3	158794-0-01	159400-0-01	148698-0-01	148685-0-01			
	-5		155722-0-01	148699-0-01	148681-0-01			
5/32 inch (4.0 mm)	-3	158796-0-01	158785-0-01	148700-0-01	148689-0-01			
	-5		155724-0-01	148701-0-01	148683-0-01			
3/16 inch (4.8 mm)	-3	158791-0-01	158784-0-01	148702-0-01	148687-0-01			148585-0-01
	-5		155851-0-01	148703-0-01	148691-0-01			
1/4 inch (6.4 mm)	-3	158792-0-01	158783-0-01	148704-0-01	148693-0-01			
	-5		155853-0-01	148705-0-01 ※158756-0-01	148695-0-01			
5/16 inch (7.9 mm)	-3	158793-0-01	159402-0-01	149692-0-01	149689-0-01			149697-0-01
	-5		155855-0-01	149691-0-01	149687-0-01			
3/8 inch (9.5 mm)	-3	158798-0-01	149946-0-01	149939-0-01	149942-0-01			
	-5		155857-0-01	149938-0-01	149940-0-01			
1/2 inch (12.7 mm)	-3	158797-0-01	159404-0-01	149676-0-01	149673-0-01	149685-0-01		
	-5		149677-0-01	149675-0-01	149671-0-01			
5/8 inch (15.9 mm)	-3	158795-0-01	149956-0-01	149949-0-01	149952-0-01	149958-0-01		
	-5		149954-0-01	149948-0-01	149950-0-01			
3/4 inch (19.1 mm)	-5	158806-0-01	150526-0-01	150523-0-01	150524-0-01	150528-0-01	149986-0-01	
7/8 inch (22.2 mm)	-5	158807-0-01	150534-0-01	150531-0-01	150532-0-01	150536-0-01		
1 inch (25.4 mm)	-5	158805-0-01	149966-0-01	149960-0-01	149962-0-01	149970-0-01		

- ◎The needle hole in the feed dogs is for extra-heavy thread. (※Mark)
- ◎Das Nadelloch im Transporteur ist für dicken Faden. (Marke※)
- ◎Trou de passage de l'aiguille dans les griffes d'entraînement pour fil extra-fort. (※Marque)
- ◎El agujero de la aguja en el alimentador es para hilo exraduro. (Marca※)

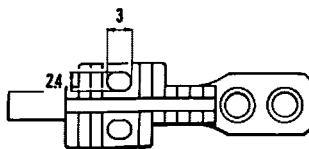

INDEX / VERZEICHNIS INDEX / INDICE

Parts No.	Ref. No.	Remark	Parts No.	Ref. No.	Remark	Parts No.	Ref. No.	Remark	Parts No.	Ref. No.	Remark
S00896-0-00	P-82		025680-1-33	Z-47		062711-6-12	E-35		108265-0-01	B-19- 5- 1-11	
S00897-0-00	P-82- 1		025710-2-32	E-34		062761-4-12	H-16		108266-0-01	B-12	
S00899-0-00	P-82- 2			J-28		062782-5-12	E-48				
001061-6-06	U- 1-10		025750-1-32	Z-24- 4- 6			G-17		108549-0-01	L-92	
001630-4-02	P-11		028030-2-43	T- 7		072620-4-60	C-18		108960-0-02	B-13	
001670-6-12	L-64		028040-2-43	U- 1- 8		081016-0-70	L-77			B-15	
002303-0-06	T- 5		028050-2-43	T- 1-15		100022-0-05	P-55			B-17	
002400-8-03	P-19			Z-16- 9		100032-0-04	S- 4			B-22	
002501-0-03	T- 1-14		028060-2-42	U- 1-12		100064-0-02	B- 6		109268-0-01	U- 1-14	
005671-2-12	K- 7		028060-2-43	Z-49- 2- 6		100078-0-03	P-39		109714-0-00	L-71	
007401-0-12	M- 2		028680-2-42	L-56		100197-0-02	J-25			Z-40	
007500-6-02	E-51			Z-24- 4- 4		100242-0-03	L-62		110161-0-06	J-12	
	G-32		031452-2-03	Z-16- 2		100248-0-01	L-69		110171-0-01	G-14	
007500-8-02	G-18			Z-16-17		100250-0-01	C- 5			Q-10	
007501-0-03	Z-16-15		047501-2-42	E-25- 4		100251-0-01	C-10		112072-0-01	F-21	
009679-3-12	Z-14-22		048040-3-42	E-38			K-18		112560-0-03	A- 2	
009781-8-12	D- 9			G- 8		100289-0-03	P-28		112561-0-03	A- 5	
	F-39			N- 8		100320-0-02	J- 3		112566-0-03	A-13	
011802-0-12	P-38		048060-3-42	F-37			J-24		112569-0-01	Z-37	
013710-7-12	E-42		048070-3-42	F-13		100328-0-01	F-10		112572-0-01	C- 1	
013760-6-10	E- 3		048090-3-42	M- 1- 3		100366-0-02	Z-14-13		112573-0-01	C- 2	
013761-4-10	C- 3		062660-4-12	L-90		100401-0-01	Z-14- 4		112574-0-00	C- 4	
	C-13		062661-2-12	H-18		100477-0-01	Z-11- 1		112576-0-01	C- 7	
	C-17		062670-4-12	L-12		100645-0-03	G-54		112577-0-01	C- 8	
	C-25			M- 8			L-57		112578-0-01	C-11	
	F-14		062670-5-12	L-27		100657-0-01	Z-14-15		112579-0-01	C-12	
	H- 2			L-32		100659-0-01	Z-14-17		112586-0-01	C-23	
	H- 6			L-34- 1		100662-0-01	Z-14-20		112589-1-00	D- 1- 2	
013771-2-12	C-21			L-34- 2		100666-0-02	Z-15		112590-0-01	D- 1- 4	
	K- 9			L-36- 1			Z-24- 4- 5		112592-0-01	D- 1- 7	
				L-36- 2		100887-0-01	Z- 4- 1		112593-0-01	D- 1- 9	
013780-7-10	K- 5			L-38		101118-0-01	T- 2		112594-0-01	D- 2	
014760-6-22	F-28		062670-6-12	A-14		101268-0-02	D- 7		112595-0-00	D- 3	
	G-10			A-29		101572-1-01	Z- 3- 4		112596-0-01	D- 5	
014770-6-22	P-15			A-31		101706-0-01	C- 9		112597-0-01	D- 6	
	P-44			B- 8			F- 3- 2		112598-0-01	D- 8	
015771-0-12	F-26			L- 9			H-21		112603-0-01	S- 3	
	G- 3		062670-8-12	D- 1- 8			K-20		112604-0-01	S- 3	
015771-2-12	C-20			E- 5		102571-0-03	N-12		112605-0-01	S- 3	
	K-10			J-19		102731-0-04	D- 1- 5		112606-0-01	D-10	
017502-8-03	Z-16- 7		062671-0-12	L-79		104908-0-04	E-24		112607-0-01	D-11	
	Z-16-19		062680-6-16	Z-46			H-14		112610-0-01	D-14	
018061-6-22	P- 2		062680-7-12	E- 9- 1- 2		105161-0-02	J-18		112614-0-01	E- 1	
021060-1-06	Z-49- 1- 2			E- 9- 2- 2		105161-0-03	N-14		112615-0-01	E- 2	
	Z-49- 2- 4			K-13		105234-0-03	L-58		112616-0-01	E- 4	
021060-2-06	U- 1-13			R- 7		105351-0-02	D- 4		112618-0-01	E- 7	
021300-1-03	T- 6		062680-8-12	Z-24- 4- 3			J-26		112619-0-01	E- 8	
021500-1-03	Z-16- 4- 3		062681-0-12	A- 4		106030-0-01	E-30		112623-0-01	E-12	
	Z-16-10			B-11		106640-0-01	L-18		112624-0-01	E-13	
	Z-16-16			F- 1- 3		107030-0-01	D- 1- 3		112625-0-01	E-14- 1	
021500-1-04	U- 1- 4			N- 7		107155-0-01	L-78		112626-0-01	E-15	
021660-1-02	H-19		062681-4-12	N-11		107231-0-02	A- 6		112628-0-01	E-17	
021670-1-02	B-19- 1-22		062681-6-12	A- 3		107407-0-03	M- 6		112629-0-01	E-18- 1	
	B-19- 5- 7		062710-8-12	E-50			M-13		112630-0-01	E-19	
	Q-20			F-31		107415-0-11	D-16		112631-0-01	E-20	
025030-1-35	R- 2-13			L- 3			Z- 7		112636-0-01	E-25- 3	
025030-2-33	T- 8			P- 4		107415-0-14	D-16		112638-0-01	S- 5	
025030-3-35	R- 2- 4			P-62			Z- 7		112642-0-01	S- 5	
025040-1-35	R- 2-17		062711-0-12	L-29		107415-0-22	D-16		112645-0-01	S- 5	
025040-2-32	M- 3			P-20			Z- 7		112656-0-01	H-15	
025040-3-35	R- 2-15			P-60		107794-0-01	J- 5		112658-0-01	B-14	
	R- 2-20		062711-4-12	G-12			J- 8			B-21	
025050-2-33	U- 1- 5			M-17		108254-0-01	B-19- 1- 4		112659-0-01	S- 7	
	Z-16-20			P-46			B-19- 5- 1- 4		112660-0-01	S- 7	
025060-1-32	H-17			P-48		108263-0-01	B-19- 1- 7		112661-0-01	S- 7	
025060-2-36	U- 1-11			R- 3		108264-0-01	B-19- 1- 8		112666-0-00	K- 4- 1	
025630-1-32	P-12			R- 5		108265-0-01	B-19- 1-10		112667-0-01	K- 4- 2	

Parts No.	Ref. No.	Remark	Parts No.	Ref. No.	Remark	Parts No.	Ref. No.	Remark	Parts No.	Ref. No.	Remark
112668-0-01	K- 6		113362-0-01	L-67		118713-0-01	F -15- 1		143609-0-01	F -29	
112684-0-01	K-14- 2		113380-0-01	E-29		118746-0-01	F -20			P -40	
	K-17		113386-0-00	D-19		118747-0-01	F -22- 1		143610-0-01	F -30	
112685-0-01	J - 1- 1		113524-0-01	L-19		118752-0-03	F -25		143611-0-01	F -32- 1	
112686-0-01	J - 2		113526-0-01	L-16		118837-0-01	Z - 3- 3		143612-0-00	F -32- 1- 1	
112687-0-01	J - 4		114297-0-01	L-14		118853-0-01	F -19		143613-0-01	F -32- 1- 3	
112690-0-01	J - 7			L-31			F -23			F -32- 2- 3	
112691-0-01	J - 9- 1		114483-0-02	Z-12		118865-0-01	K-12		143616-0-01	F -36	
112692-0-01	J -10		114486-0-02	L-72		118945-0-01	S - 3		143657-0-01	L -17	
112694-0-01	J -13		114680-0-01	C-24		118946-0-01	S - 5		143660-0-00	L -39- 1	
112695-0-01	J -14		114693-0-01	L-65		118947-0-01	S - 7		143661-0-00	L -40- 1	
112696-0-00	J -16		114859-0-01	Z-50		118954-0-00	F -32- 1- 2		143662-0-00	L -41- 1	
	L-68		114909-0-00	E-22			F -32- 2- 2		143668-0-00	L -43- 1	
112697-0-01	J -17		114941-0-01	B-18		119710-0-01	Z -49- 1			L -84- 1	
112698-0-01	K- 4			Z-10		120311-0-02	N - 3		143669-0-00	L -44- 1	
112699-0-01	J -20		114948-0-01	S - 5		122991-0-01	Z - 1			L -85- 1	
112700-0-01	J -21		114950-0-01	S - 3		123882-0-01	Q - 3		143670-0-00	L -49- 1	
112701-0-01	J -22- 1		114951-0-01	S - 7		126863-0-00	Z -16-13		143671-0-00	L -50- 1	
112702-0-01	J -23		115177-0-01	Q-18		129984-0-02	A -34		143673-0-01	L -89	
112706-0-01	B-19- 1- 6		115249-0-01	L-94		133792-0-01	Z -49- 2		143766-0-01	L -87	
112709-0-01	B- 7		115287-0-00	J -29		133797-0-01	Z -49		143910-0-01	Z -38	
112712-0-01	B-19- 1-13		116010-0-01	D-15		140525-0-01	C -11		143960-1-01	T - 1- 1- 2	
	B-19- 5- 1-15		116283-0-01	S - 8		140527-0-01	B - 1		144189-0-01	T - 9	
112713-0-01	B- 9- 2		116323-0-01	S - 1- 2		140538-0-00	T - 1- 1- 4		144222-0-01	Z -17	
112714-0-00	B-10- 1		116498-0-01	S - 5		140540-0-00	T - 1- 9		144458-0-01	D-24	
112715-0-01	B-16		116499-0-01	S - 5		140543-0-00	T - 1- 7		144504-0-01	B -19- 5- 4	
112716-0-01	L - 1		116500-0-01	S - 5		140620-0-01	E -36		144614-0-01	C -16	
112717-0-01	L - 2		116501-0-01	S - 5		140643-0-00	N - 4- 1		144678-0-01	B -19- 1	
112719-0-01	L - 5		116502-0-01	S - 5		140678-0-00	T - 1- 1- 3		144680-0-01	B -19- 1- 2	
112720-0-01	L - 6		116503-0-01	S - 3		140682-0-01	T - 1- 3			B -19- 5- 1- 2	
112721-0-01	D- 1-10		116504-0-01	S - 3		140693-0-00	T - 4- 4		144681-0-01	B -19- 1- 3	
112723-0-01	L-15		116505-0-01	S - 3		140947-0-02	U - 1- 6		144682-0-01	B -19- 1- 5	
112724-0-01	L-13		116506-1-01	S - 3		140948-0-01	T - 4- 2			B -19- 5- 1- 5	
112725-0-01	L-10		116507-0-01	S - 3		140950-0-00	T - 4- 3		144683-0-01	B -19- 1-12	
112728-0-01	L-51		116508-0-01	S - 7		140953-0-01	U - 1- 3			B -19- 5- 1-14	
112730-0-01	L-11		116509-0-01	S - 7		141439-0-01	E -40		144685-0-01	B -19- 1-17	
112734-0-01	L-20		116510-1-01	S - 7		141494-0-01	E -44		144686-0-01	B -19- 1-18	
112735-0-00	L-21		116511-0-01	S - 7			P -50		144687-0-01	B -19- 1-19	
112735-0-01	L-22		116512-0-01	S - 7			P -56		144688-0-01	B -19- 1-20	
112736-0-00	L-23		116558-0-01	L-76		141748-0-01	G -37		144689-0-01	B -19- 1-21	
112737-0-01	L-24- 1		116699-0-00	L - 4		142002-0-01	Z - 4-11		144703-0-01	B -19- 1-14	
112738-0-00	L-25- 1		117133-0-01	S - 3		142037-0-00	T - 1- 5			B -19- 5- 1-16	
112739-0-01	L-26		117134-0-01	S - 7		142038-0-01	T - 1- 6		144704-0-01	B -19- 1-15	
112741-0-01	L-30- 1		117158-0-01	S - 3		142105-0-01	S - 5		144823-0-01	B - 9- 1	
112743-0-01	L-33- 1		117160-0-01	Q-15		142110-0-01	S - 7		144881-1-01	S - 3	
	L-33- 2			S - 4		142111-0-01	S - 3		144882-0-01	S - 3	
112744-0-01	L-35- 1		117200-0-01	L - 7- 2		142268-0-01	A -28		144903-0-01	J - 9- 1	
	L-35- 2		117203-0-01	L-80		142443-0-01	Z - 3- 1		144947-0-01	S - 7	
112745-0-01	L-37		117204-0-01	L-81		142721-0-01	Z - 4-12		144949-0-01	S - 5	
112751-0-03	D-17		117205-0-01	L-82		142746-0-02	F - 8		144951-0-01	S - 3	
112753-0-01	L-52		117281-0-01	S - 5		142747-0-02	F - 7		145328-0-01	F - 1- 4	
112754-0-01	L-53		117365-0-01	S - 7		142990-0-01	Z -16-18- 4		145446-0-01	B -19- 5- 1- 8	
112755-0-00	L-54		117366-0-01	S - 7		143488-0-01	T - 4- 6			Z -14- 3	
112756-0-01	L-55		117367-0-01	S - 3		143489-0-01	T - 1-17		145502-0-01	F - 9	
112757-0-01	L-59- 1		117368-0-01	S - 3			T - 4- 7		145596-0-01	T - 1-11	
112758-0-01	L-60		117369-0-01	S - 3		143499-0-00	T - 1-16		145721-0-01	D-10	
112759-0-01	L-61		117370-0-01	S - 3		143548-0-00	T - 1-18		145946-0-01	Z -45	
112760-0-01	C-26		117963-0-01	Z-14		143549-0-00	G - 6- 5		146080-0-00	M-22	
112762-0-01	L - 7- 1		117969-0-01	Z-14-10			M - 1- 5			N - 9	
112763-0-01	E-26		117970-0-01	Z-14-11			N - 4- 3		146105-0-00	G-31	
112764-0-01	D-18		117971-0-01	Z-14-12			P -16- 4		146118-0-00	T - 1-10	
112781-0-01	J -27- 1		118170-1-01	E-28			T - 1-13		146124-0-01	N - 5	
	Z - 9		118171-0-01	C-14			T - 4- 5		146141-0-01	C - 6	
113014-0-00	C-27		118317-0-01	B-19- 1- 9		143591-0-01	H-13		146153-0-01	E-37	
113024-0-00	C-15		118320-0-01	B-19- 1-16		143594-0-01	F - 1- 2		146160-0-01	T - 4	
113050-0-01	S - 6			B-19- 5- 1-18		143597-0-01	F - 2		146175-0-01	U - 1	
113074-0-01	H-20		118713-0-01	E-41		143608-0-01	F -27		146178-0-01	U - 1- 2	

Parts No.	Ref. No.	Remark	Parts No.	Ref. No.	Remark	Parts No.	Ref. No.	Remark	Parts No.	Ref. No.	Remark
146358-0-01	U- 1-15		148575-0-01	P-45		148737-0-01	L-85- 2		149970-0-01	P-49	
146598-0-01	A- 8		148579-0-01	P-57		148738-0-00	L-84- 2		149986-0-01	M-23	
147560-0-01	S - 3		148581-0-01	P-49		148740-0-00	L-41- 2		149991-0-01	E-46	
147561-0-01	S - 7		148584-0-01	P-49- 2		148741-0-01	L-40- 2		150106-0-01	Z-16- 4	
147562-0-01	S - 5		148585-0-01	P-49		148742-0-00	L-39- 2		150139-0-01	Z-16- 1	
147856-0-02	Z-24- 4- 1		148587-0-01	P-51		148743-0-01	L-95		150151-0-03	Z-16	
147858-0-01	Z-24- 4- 2		148589-0-01	P-52		148762-0-01	L-63		150172-0-01	Z-16- 3	
147908-0-01	Z-24		148591-0-01	P-53		148764-0-01	G-26		150176-0-01	Z-16- 6	
148005-0-01	J -11		148592-0-01	P-54		148768-0-01	Q-13			Z-16-18- 1	
148011-1-01	B-19- 1		148593-0-00	P-10		148770-1-01	M-16		150179-0-01	Z-16- 8	
148394-0-00	L-75		148594-0-00	P-10		148771-0-01	F- 1		150180-0-00	Z-16-11	
148480-0-01	J -22- 2		148599-0-01	D-14		148801-0-01	F-32- 2		150181-1-01	Z-16- 1- 2	
148481-0-01	J - 1- 2		148601-0-01	J-32		148802-0-01	F-35- 1		150182-0-00	Z-16-12	
148482-1-01	P - 1		148603-0-01	J -27- 2		148803-0-01	K- 8		150184-0-01	Z-16-18- 5	
148483-0-01	E - 6			Z- 9		148804-0-01	K-14		150188-0-01	Z-16-14	
148486-0-01	E-14-1, 14-2		148604-0-00	B-10- 2		148818-0-01	A-30		150193-0-03	Z-16-18	
148487-0-01	F-17		148605-0-01	E-53		148821-0-01	K-10		150202-0-01	Z-16- 4- 2	
148488-0-01	F-12		148607-0-02	G- 2		148825-0-01	R - 4		150381-0-01	Z-48	
148489-0-01	F-11- 1		148608-0-01	G- 4		148835-0-01	E- 9-1, 9-2		150523-0-01	S - 7	
148490-0-01	H-11		148611-0-01	A-25		148882-0-01	Z-36- 1		150524-0-01	S - 5	
148491-0-01	H-12		148614-0-01	A-26		148890-1-01	Z-39		150526-0-01	S - 3	
148492-0-01	H- 7		148615-0-01	R- 1		148924-1-01	B-19- 1- 9		150528-0-01	P-49	
148493-0-01	H- 1		148619-0-01	Q- 1		148977-0-01	H-12		150531-0-01	S - 7	
148494-0-01	H- 5		148623-0-01	Q- 2		149001-0-01	H- 7		150532-0-01	S - 5	
148495-0-01	F-38		148625-0-01	Q- 5		149010-0-00	Z-11- 2		150534-0-01	S - 3	
148496-0-00	F-32- 2- 1		148628-0-01	Q- 6		149024-0-01	E-39		150536-0-01	P-49	
148499-0-01	F-18			Q- 9		149025-0-01	E-43		150553-0-03	B - 2	
148500-0-01	F-18		148629-0-01	Q- 7		149027-0-01	E-45		150557-0-01	Z-36- 3	
148501-1-01	F-15- 2		148630-0-01	Q- 8		149063-0-01	G-42		150850-0-01	S - 3	
	F-15- 3		148631-0-01	Q-11		149169-0-01	P - 8- 2		150917-0-01	D-25	
148502-0-00	K- 3		148632-0-01	Q-12			Z-31- 2		151007-1-01	L-70	
148503-0-00	K- 2		148633-0-01	Q-17		149174-0-01	G- 7		151076-0-01	S - 5	
148508-0-01	M-15		148634-0-01	Q-14		149177-0-01	D-26		151078-0-01	S - 7	
148511-0-01	M- 1- 2		148635-0-01	Q-16			M-21		151029-0-01	J - 9- 1- 2- 7	
148512-0-00	M- 1- 4		148638-0-01	G- 9		149179-0-01	A-32			J - 9- 7- 2- 7	
148513-0-02	M- 5		148640-0-01	G-11		149288-0-02	A-27		151030-0-01	J - 9- 1- 2- 8	
148514-0-02	M- 7		148654-0-01	Q-19		149311-0-01	S - 5			J - 9- 7- 2- 8	
148515-0-01	M- 9		148655-0-01	P-61		149312-0-01	S - 5		151080-0-01	F-24	
148516-0-01	M-11		148674-0-01	E-29		149554-0-01	G-53		151081-0-01	H-11	
148517-0-00	M-12		148679-0-01	S - 5		149671-0-01	S - 5		151082-0-01	K- 1	
148518-0-00	M-14		148681-0-01	S - 5		149673-0-01	S - 5		151083-0-01	L-28- 1	
148521-0-01	M-10		148683-0-01	S - 5		149675-0-01	S - 7		151084-0-00	L-42- 1	
148527-0-01	M-18		148685-0-01	S - 5		149676-0-01	S - 7		151101-0-02	A- 7	
148528-0-01	M-23		148687-0-01	S - 5		149677-0-01	S - 3		151145-0-01	J - 9- 1- 2- 6	
148529-0-01	M-19		148689-0-01	S - 5		149685-0-01	P-49			J - 9- 7- 2- 6	
	Z-33		148691-0-01	S - 5		149687-0-01	S - 5		151146-0-01	J - 9- 1- 2- 6	
148530-0-01	M-20		148693-0-01	S - 5		149689-0-01	S - 5		151147-0-01	T - 1- 4	
	Z-34		148695-0-01	S - 5		149691-0-01	S - 7		151153-1-01	T - 1- 1	
148536-0-01	P - 6		148697-0-01	S - 7		149692-0-01	S - 7		151191-0-01	D-23	
148537-0-01	P - 7		148698-0-01	S - 7		149697-0-01	P-49		151507-0-01	F - 6	
148538-0-01	P - 8- 1		148699-0-01	S - 7		149768-0-01	E-18- 2		151508-0-01	F - 6	
	Z-31- 1		148700-0-01	S - 7		149873-0-01	N- 2		151596-0-01	S - 3	
148539-0-01	P - 9		148701-0-01	S - 7		149938-0-01	S - 7		151597-0-01	S - 5	
	Z-32		148702-0-01	S - 7		149939-0-01	S - 7		151598-0-01	S - 7	
148545-0-01	P-16- 3		148703-0-01	S - 7		149940-0-01	S - 5		151601-0-02	E-25- 2	
148546-0-01	M- 4		148704-0-01	S - 7		149942-0-01	S - 5		151602-0-01	F-16	
	P-17		148705-0-01	S - 7		149946-0-01	S - 3			F-41	
148547-0-01	P-21		148728-0-01	L-59- 2		149948-0-01	S - 7		151602-0-02	A-24	
148548-0-01	P-22		148729-0-01	L-28- 2		149949-0-01	S - 7		151605-0-01	E-27	
148554-0-01	P-27		148730-0-01	L-24- 2		149950-0-01	S - 5			F-35- 1- 2	
148555-0-01	P-25		148731-0-00	L-25- 2		149952-0-01	S - 5			F-35- 2- 2	
148557-0-01	P-30		148732-0-01	L-30- 2		149954-0-01	S - 3			K-19	
148559-0-00	P-24		148733-0-01	L-42- 2		149956-0-01	S - 3		153112-0-01	A-33	
148561-1-01	P-18			L-50- 2		149958-0-01	P-49		153168-0-01	F - 5	
148573-0-01	P-42		148734-0-00	L-49- 2		149960-0-01	S - 7		153243-0-01	J -36	
148574-0-01	P-14		148735-0-01	L-44- 2		149962-0-01	S - 5		153244-0-01	J -36	
	P-43		148736-0-00	L-43- 2		149966-0-01	S - 3		153483-0-01	J -15	

Parts No.	Ref. No.	Remark	Parts No.	Ref. No.	Remark	Parts No.	Ref. No.	Remark	Parts No.	Ref. No.	Remark
153484-0-01	D-28		158799-0-01	S - 1		107415-0-21	D-16				
153969-0-00	P-80		158800-0-01	S - 1			Z - 7				
153971-0-01	P-81		158801-0-01	S - 1		150836-0-01	D-10				
154327-0-01	J - 9- 5		158802-0-01	S - 1		151027-0-01	J - 9- 1- 1- 9				
154518-0-01	J - 9- 5- 3- 2		158803-0-01	S - 1			J - 9- 5- 1- 9				
	J - 9- 8- 3- 2		158804-0-01	S - 1			J - 9- 7- 1- 9				
154519-0-01	J - 9- 5- 3- 3		158805-0-01	S - 1			J - 9- 8- 1- 9				
	J - 9- 8- 3- 3		158806-0-01	S - 1		151030-0-01	J - 9- 5- 3- 4				
			158807-0-01	S - 1			J - 9- 8- 3- 4				
			158808-0-01	S - 1		151132-0-01	J - 9- 1- 1				
154702-0-01	Z-13		158809-0-01	S - 1		151138-0-01	J - 9- 1- 2				
154729-0-01	G- 6- 2					151139-0-01	J - 9- 1- 2				
154730-0-01	G- 6- 3		158814-0-01	P -26		154515-0-01	J - 9- 5- 1				
154731-0-00	G- 6- 4					154516-0-01	J - 9- 5- 2				
154734-0-01	G- 6		159350-0-01	N-10		159326-0-01	J - 9- 7- 2				
155447-1-01	E-21		159359-0-01	D- 1		159837-0-01	J - 9- 8- 2				
155451-0-01	F-35- 2		159360-0-01	D- 1- 6		159931-0-01	J - 9- 1- 1				
155491-0-01	B -19- 5- 1- 3		159361-0-01	F - 4		159945-0-01	J - 9- 7- 1				
155492-0-01	B -19- 5- 1-10		159362-0-01	P - 3							
155505-0-01	E-16		159365-0-01	P - 5		159937-001	J - 9- 5- 3				
155510-0-01	B -19- 5- 6		159366-0-01	P -41							
155522-0-01	D-27		159398-0-01	S - 3							
155722-0-01	S - 3		159400-0-01	S - 3							
155724-0-01	S - 3		159402-0-01	S - 3							
155851-0-01	S - 3		159404-0-01	S - 3							
155853-0-01	S - 3		159429-0-01	G- 5							
155855-0-01	S - 3		159436-0-01	E-23							
155857-0-01	S - 3		159605-0-01	E-33							
156362-0-01	G- 1		159606-0-01	E-47							
156479-0-00	N-10- 2		159607-0-01	E-49							
156546-0-01	M- 1		159608-0-01	E-52							
156548-0-01	N- 4		159621-0-01	E-31							
156550-0-01	P-16		159805-0-01	B -19- 5- 1- 9							
156824-0-01	E-25		159813-0-01	T - 1							
156956-0-01	F-40		159814-0-00	T - 1- 2							
156997-0-01	N- 1		159839-0-01	J - 9- 5- 3							
156998-0-01	N- 6			J - 9- 8- 3							
157999-0-01	N-13		159896-0-00	N- 4							
158747-0-01	F-11- 2		159898-0-01	M- 1							
158748-0-01	F-22- 2		159900-0-01	P -16							
158749-0-01	C-16		159902-0-01	G- 6							
158750-0-01	K- 1		180157-0-01	C-19							
158751-0-01	P-47		180164-0-01	K- 8							
158752-0-01	G-16		180321-0-01	F - 3							
158753-0-01	G-15		180949-0-01	K-16							
158756-0-01	S - 7		180950-0-01	E - 9- 1							
158760-0-01	J - 9- 7		181486-0-01	K-14							
158762-0-01	J - 9- 8		181712-0-01	P -29							
158764-1-01	B -19- 5		181713-0-01	P -31							
158769-0-01	B -19- 5- 1-17		200190-0-01	T - 3							
158770-0-01	B -19- 5- 3		212251-0-01	U - 1- 7							
158771-0-01	B -19- 5- 2		215083-0-01	R - 2- 5							
158772-0-01	P -13			R - 2-14							
158775-0-01	R - 6		217093-0-01	R - 2-16							
158776-0-01	R - 8			R - 2-18							
158782-1-01	B -19- 5- 5			R - 2-21							
158783-0-01	S - 3		219557-0-00	R - 2- 6							
158784-0-01	S - 3										
158785-0-01	S - 3		219558-0-00	R - 2- 7							
158791-0-01	S - 1		219559-0-01	R - 2- 8							
158792-0-01	S - 1		221421-0-01	R - 2- 9							
158793-0-01	S - 1		224357-0-01	R - 2							
158794-0-01	S - 1		503093-0-01	L - 8							
158795-0-01	S - 1										
158796-0-01	S - 1		S00881-0-01	J - 9- 8- 1							
158797-0-01	S - 1		S01278-0-01	N-12							
158798-0-01	S - 1		025680-2-32	N-12- 4							